

FIELD NOTCH
ZEE CLOSURE
AT RIB

NON-SKINNING BUTYL
SEALANT APPLIED TO
ENDS OF ZEE CLOSURE

INSTALLATION NOTE:
CLOSE HEM OF PANELS
WITH DUCK BILLS TO
ALLOW NOTCHED ZEE
CLOSURE TO FIT
TIGHTLY TO PANEL

SECTION X-X

3/16"x7/8" BUTYL TAPE

1/4-14 X 7/8" HWH SCOTS
W/NEO. WASHER PAINTED
@ RIBS AND MIN. (1)
BETWEEN RIBS OR
MAX. 9" CTRS.

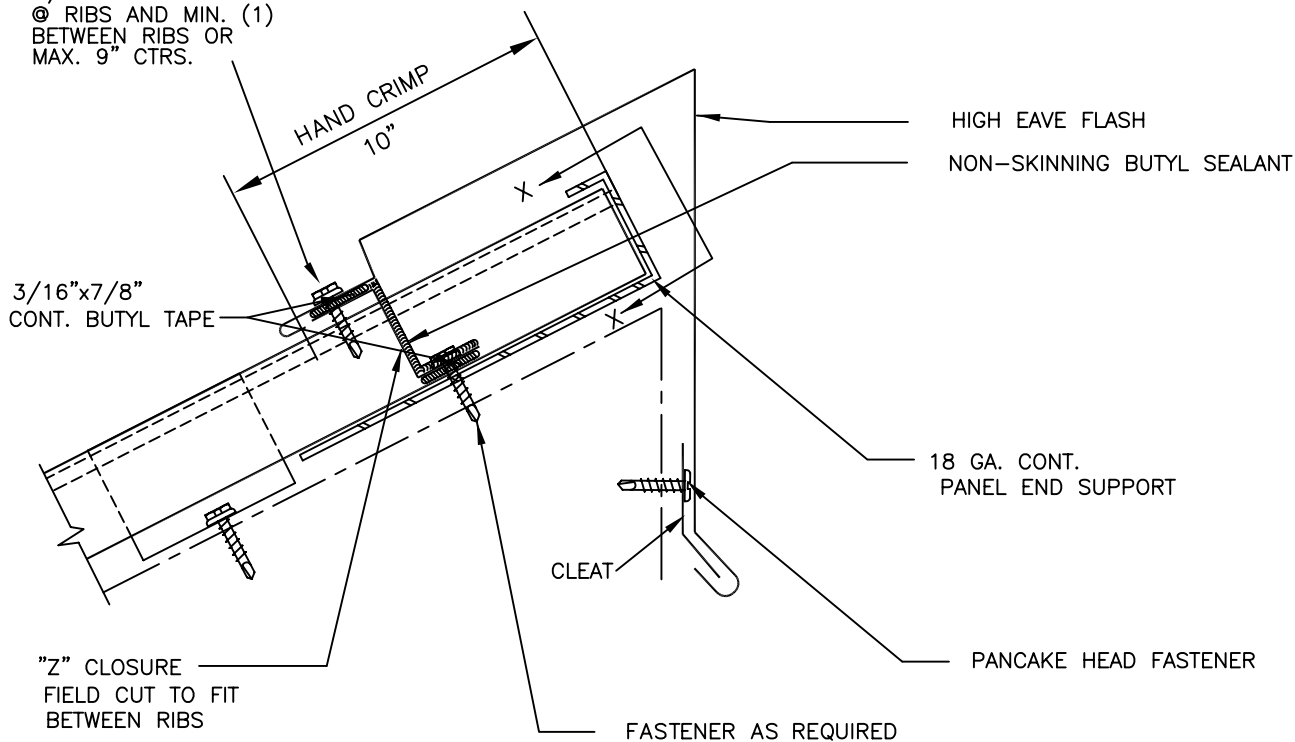

"Z" CLOSURE
FIELD CUT TO FIT
BETWEEN RIBS

HIGH EAVE FLASH

NON-SKINNING BUTYL SEALANT

18 GA. CONT.
PANEL END SUPPORT

CLEAT

PANCAKE HEAD FASTENER

FASTENER AS REQUIRED



SPAN-LOK hp

HIGH EAVE - FLOATING

SLHP-13