

DESIGN CAUTION:
 ROOF SLOPE TRANSITIONS
 SUCH AS FASCIAS MAY
 ESTABLISH AN UNWANTED
 POINT OF PANEL FIXITY.

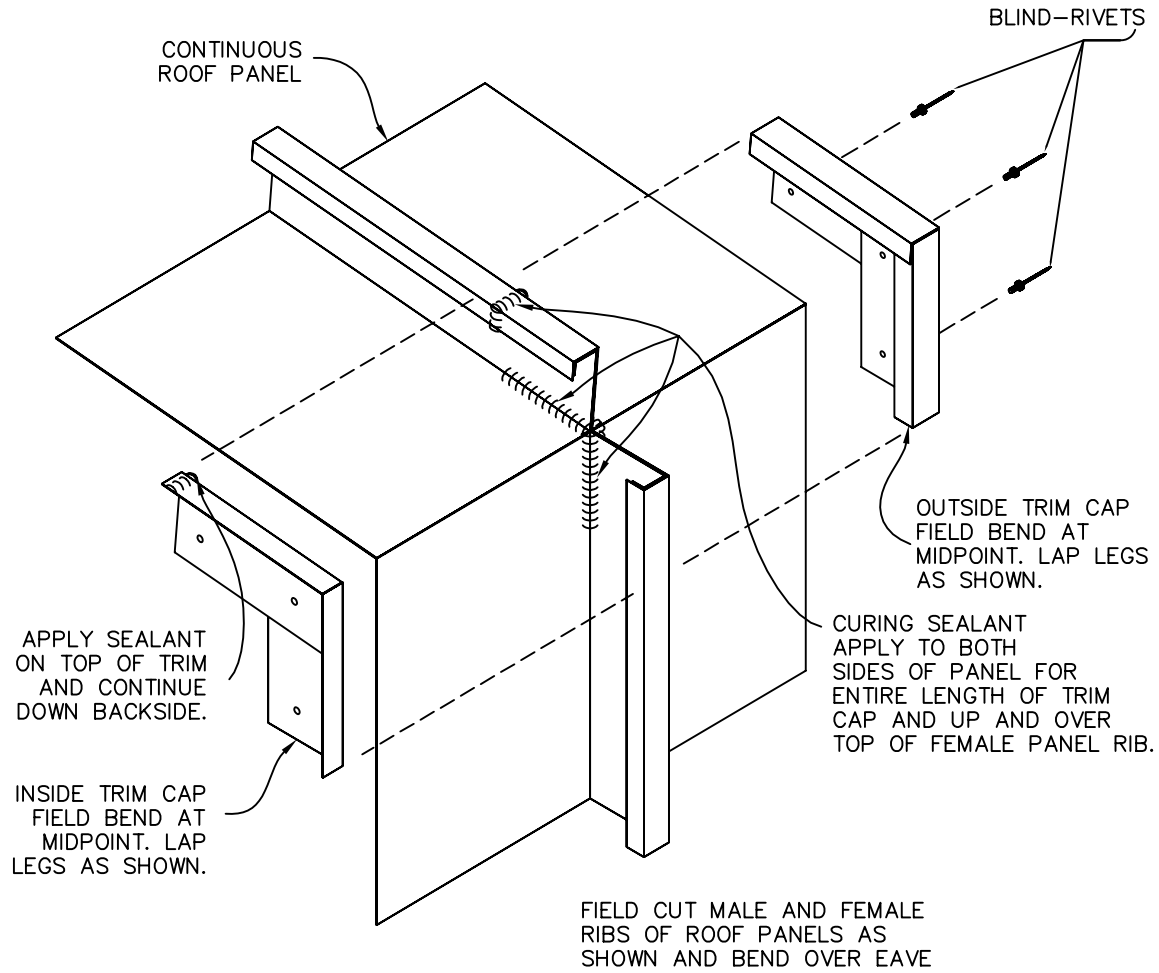

APPLY SEALANT
 ON TOP OF TRIM
 AND CONTINUE
 DOWN BACKSIDE.

INSIDE TRIM CAP
 FIELD BEND AT
 MIDPOINT. LAP
 LEGS AS SHOWN.

CURING SEALANT
 APPLY TO BOTH
 SIDES OF PANEL FOR
 ENTIRE LENGTH OF TRIM
 CAP AND UP AND OVER
 TOP OF FEMALE PANEL RIB.

FIELD CUT MALE AND FEMALE
 RIBS OF ROOF PANELS AS
 SHOWN AND BEND OVER EAVE

APPLY NON-SKINNING BUTYL SEALANT
 BETWEEN PANELS AT FIELD CUT.
 REFER TO EAVE DETAIL FOR
 LOCATION OF SEALANT. BEADS
 REQUIRED ON BOTH SIDES OF CUT.



SPAN-LOK

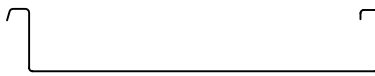

RIB COVER

SL3D4