



Design Span[®] *hp* **Installation Guide**

Design Span[®] hp

Installation Guide

- Table of Contents -

Section	Page
General Notes	i
Panel Information	1
Clip Information	2
Eave	3
Eave - with Gutter	4
Eave Hem	5
Eave - Wide Batten	6
Fascia Transition / Wall	7
Fascia Transition (3D)	8
Fascia Transition – Wide Batten	9
Gable	10
Side Wall (Rake Wall)	11
Side Wall (Alt. Details)	12
Ridge / Hip	13
Ridge / Hip (Wide Batten)	14
Ridge - Vented	15
Head Wall	16
Eave - High	17
Slope Transition	18
Valley	19
Roof Penetrations	20
Roof Curb (Side Wall Flashing)	21
Roof Curb (Uphill / Downhill Detail)	22
Snow Drag Loads	Appendix A
Drag Load Resistance	Appendix B

General Notes

The attached installation details are intended to be a design aid and do not depict all situations. Modifications are the responsibility of the designer/user and should take into account climate conditions such as wind and snow, governing code requirements, and the actual usage and maintenance of the structure.

Flashings:

Where possible, flashings should be lapped away from prevailing winds. Certain flashings should be supported if it is likely that equipment (ladder, etc.) will be used against them or if foot traffic is anticipated. Check with AEP Span any time you intend to specify a prefinished flashing in a gauge or finish different than the roof panels. It is good practice to specify that all flashings be of the same material (gauge, color, finish) as the roof panels to ensure long-term durability. Field-painted flashings rarely equal the durability and color fastness of factory baked-on paint systems. The enclosed details have minimized the use of exposed fasteners where possible. The edges of flashings have also been shown hemmed to strengthen and to minimize the exposure of cut edges.

Flashing design and fabrication is generally the responsibility of the contractor. For convenience, we have provided some flashing drawings on our website at: www.aepspan.com/files/Arch_Trims_Flashings.pdf

Applicable Design Span® hp flashing part numbers are referenced within this installation guide.

Substrates:

Design Span® hp roofing panels can be used over solid substrates or over spaced supports.

Slope Requirements:

Panels should be used on slopes of 2:12 or greater. Inquire for slopes below 2:12.

Panel Attachment:

Consult the Design Span® hp fastener attachment schedule or contact your AEP Span representative for proper clip spacing and fastener size, type, and quantities to meet the project's wind uplift (negative) load requirements. The details in this guide show two fasteners per clip. A minimum of two fasteners is always recommended although three fasteners may be required based on panel load requirements.

Condensation, Insulation, & Ventilation:

It is the designer's responsibility to determine the need and composition of condensation control materials including insulation and vapor retarders, as well as ventilation requirements. Metal roofing is susceptible to condensation and its control should be carefully considered. Applications over rigid insulation may require solid blocking/framing for installation of perimeter flashings and drag load fasteners.

Underlayment:

Prior to installation, an underlayment material may be installed over the roof substrate. The designer should select and specify an appropriate material. The specified material must have a non-abrasive top surface that will not mar, scratch, or abrade the underside of the metal panels and flashings.

"Pinning" Requirements:

The panels must only be "pinned" at one location only to resist the "drag" loads caused by the panel weight, live loads, and snow loads. The intensity of the drag load is a function of the slope, the loads involved, and the length of the panels. Panels must not be pinned at more than one location otherwise damages induced by thermal movement will occur. Appendix 'A' gives the drag loads for various slopes and snow loading conditions, and Appendix 'B' shows the number of fasteners required to resist the drag loads.

Thermal Movement:

Both panels and flashings must allow for thermal movement (expansion and contraction) of the materials, especially where long lengths are used. Appropriate gaps or provisions must be provided to accommodate thermal movement.

Snow Design:

If possible, valleys, gutters, roof elevation changes and penetrations should be minimized or eliminated in snow areas. Roof penetrations should be located as close to the ridge or peak of the roof as possible to minimize accumulations of ice and snow and the effects of thermal movement of the roof panels. Premium membrane underlayments should be used. Valleys in snow areas require special consideration due to the accumulation of snow and ice from tributary roof areas.

Valleys:

Valley dimensions must be the proper width to account for slope, snow, ice, and rain conditions. Valleys should receive a premium underlayment since they are susceptible to water buildup. Valleys must have positive slope for drainage and be kept free of debris so that water does not back up and intrude under the panels.

Oil Canning:

Flat metal surfaces often display waviness commonly referred to as 'oil canning'. This can be caused by variations in raw material, processing variations, product handling, or variations in the substrate and roofing underlayments. Oil canning is a characteristic, not a defect, of panels manufactured from light-gauge metal. Panels are available with striations and are factory "corrective leveled" to minimize oil canning. Oil canning is not a cause for panel rejection. Additional information is available upon request.

References:

The Sheet Metal and Air Conditioning Contractors' National Association Inc. (SMACNA) manual is an excellent reference for sheet metal contractors. It's guidelines for underlayments, gutter and downspout size requirements, and expansion/contraction of metals and flashing joints should be followed.

Technical Assistance:

Contact your AEP Span Sales Representative for additional information.



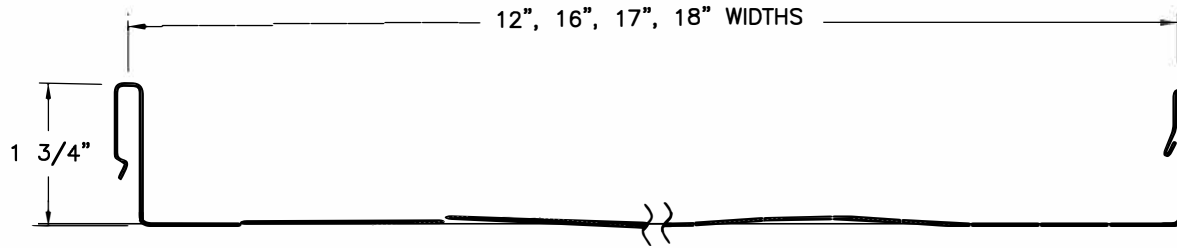

DESIGN SPAN HP PANEL

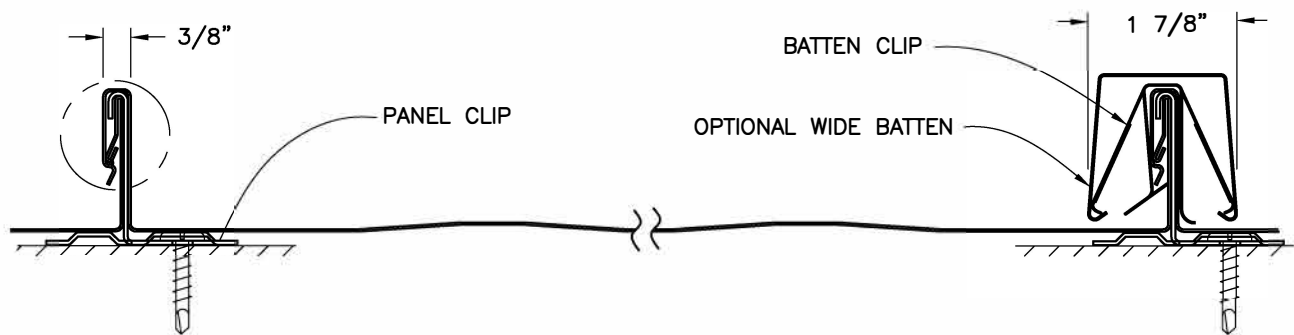

INSTALLED VIEW

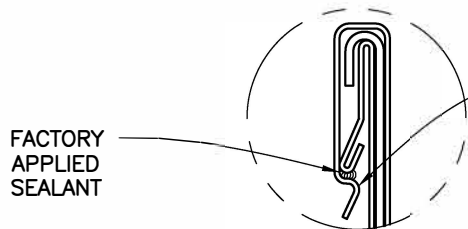

FACTORY APPLIED SEALANT

NOTE: BE CERTAIN THAT ADJOINING PANELS FULLY ENGAGE ("SNAP") TO ACHIEVE RATED PANEL PERFORMANCE.



DESIGN SPAN HP

PANEL INFORMATION



DS-01

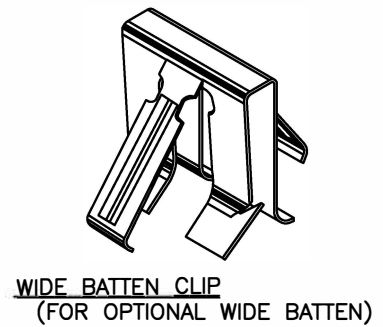
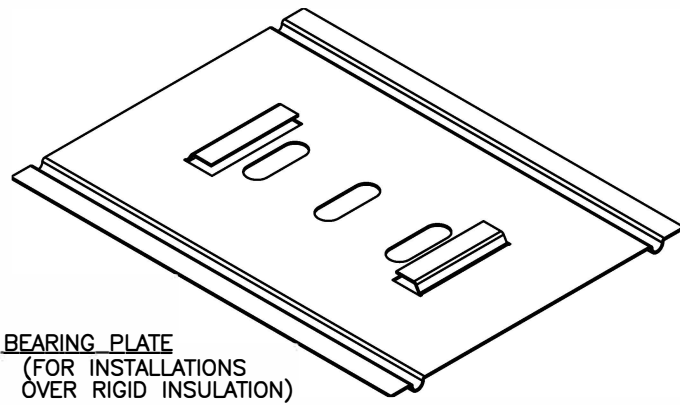
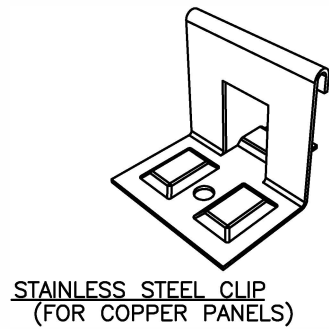
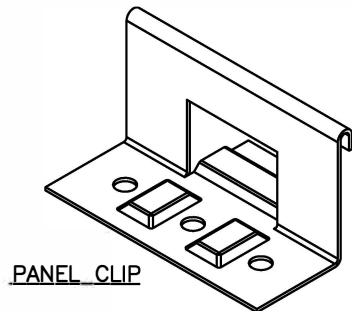
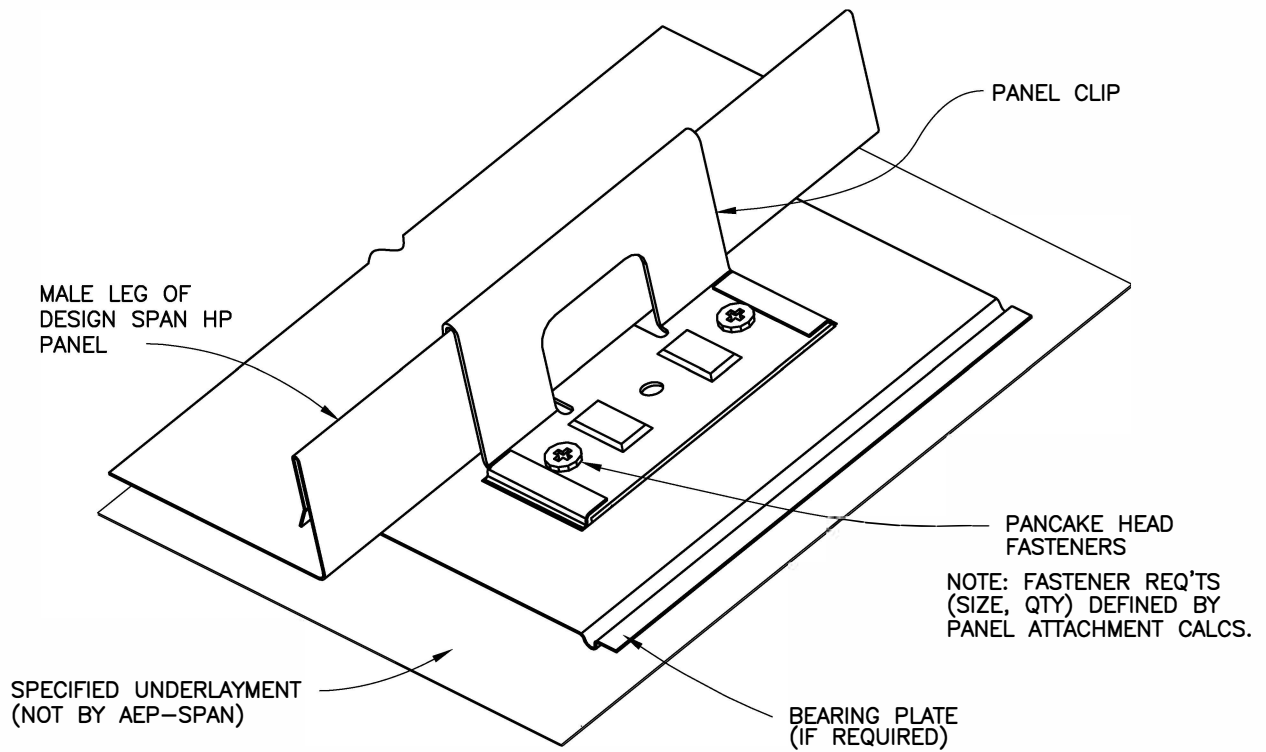

DESIGN SPAN HP



CLIP INFORMATION

DS-02

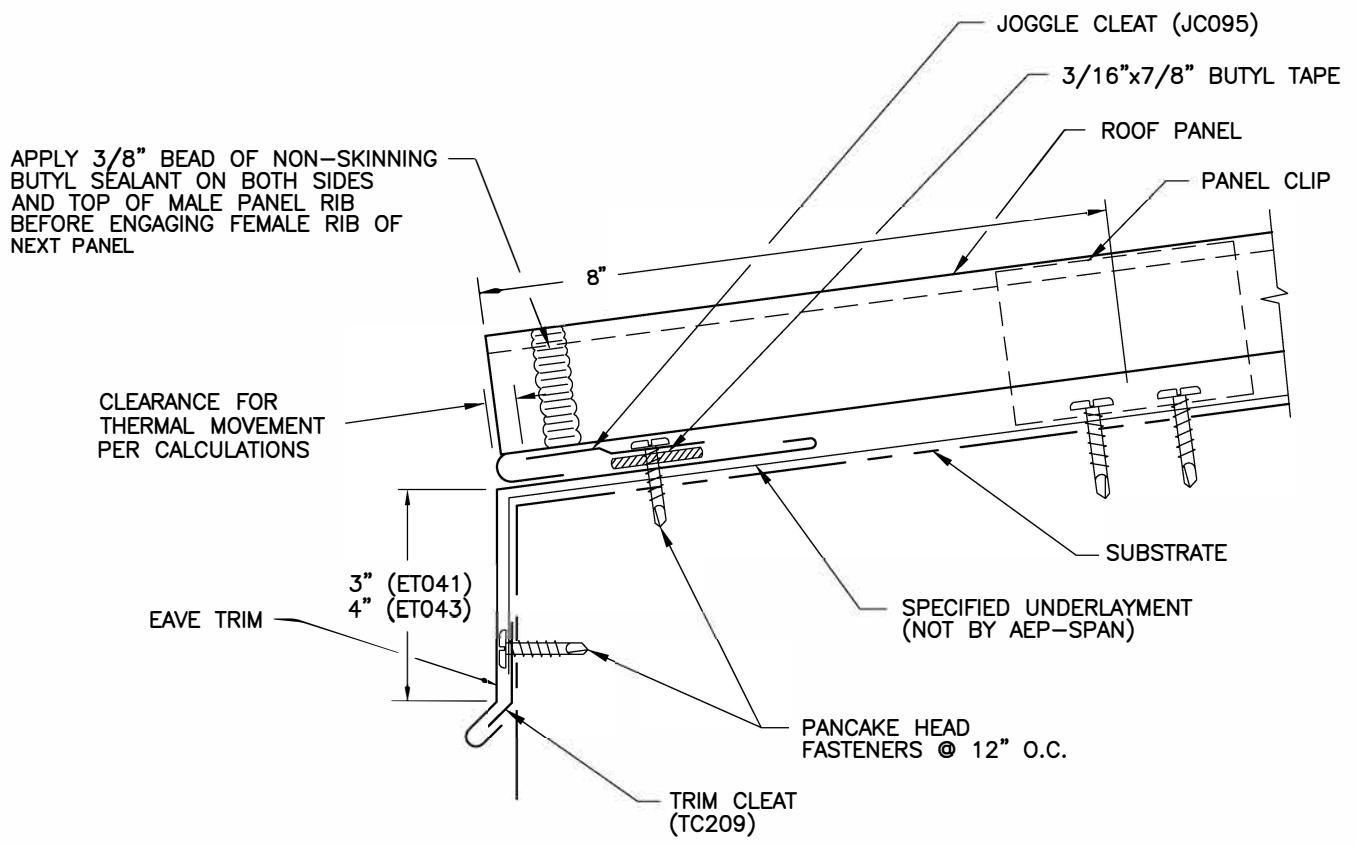
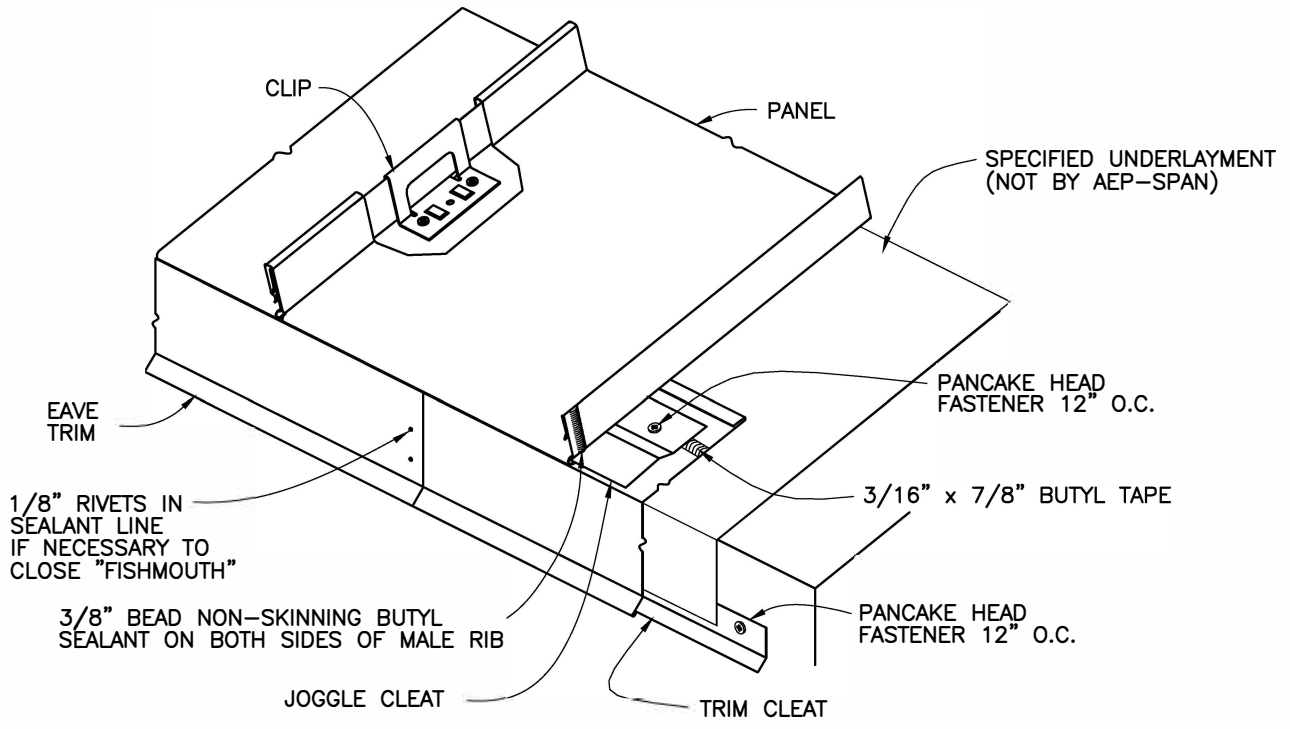

DESIGN SPAN HP

EAVE



DS-03

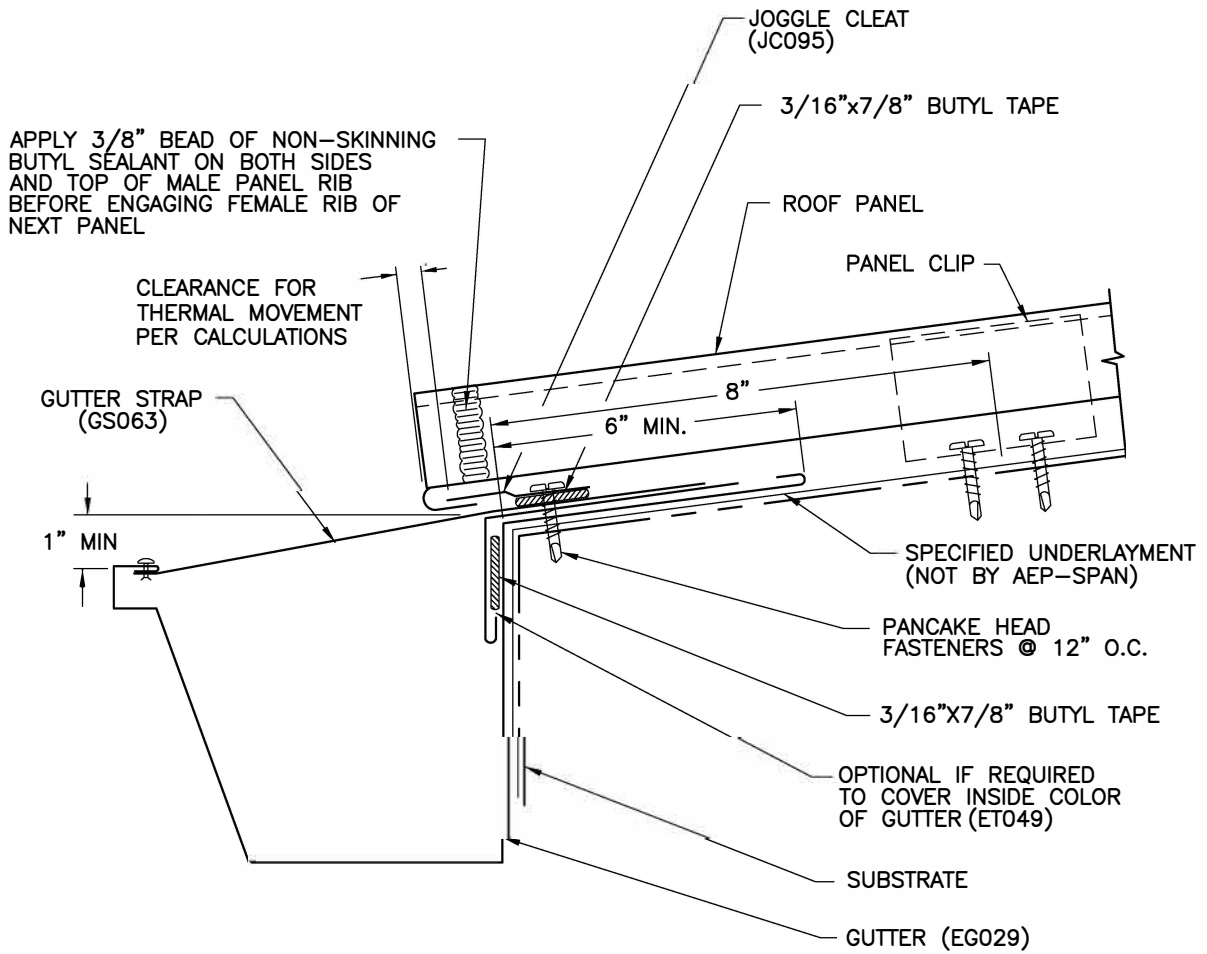

DESIGN SPAN HP

EAVE - WITH GUTTER



DS-04

STEP
1

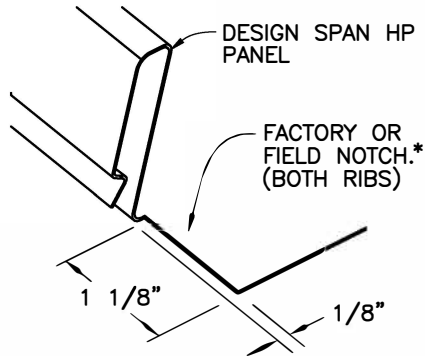

STEP
2

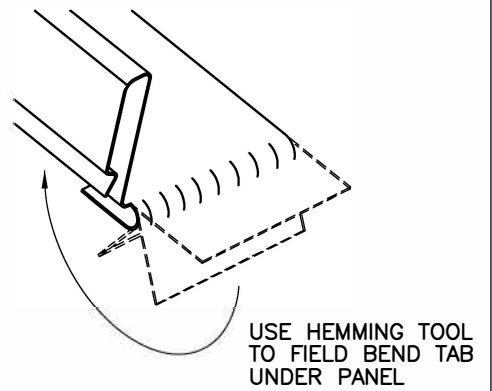

STEP
3

APPLY 3/8" BEAD OF NON-SKINNING BUTYL SEALANT ON BOTH SIDES AND TOP OF MALE PANEL RIB BEFORE ENGAGING FEMALE RIB OF NEXT PANEL

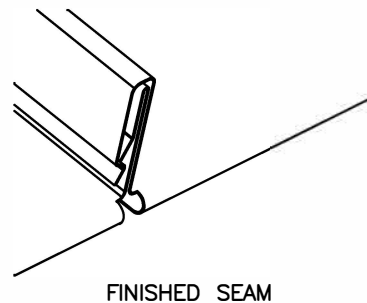
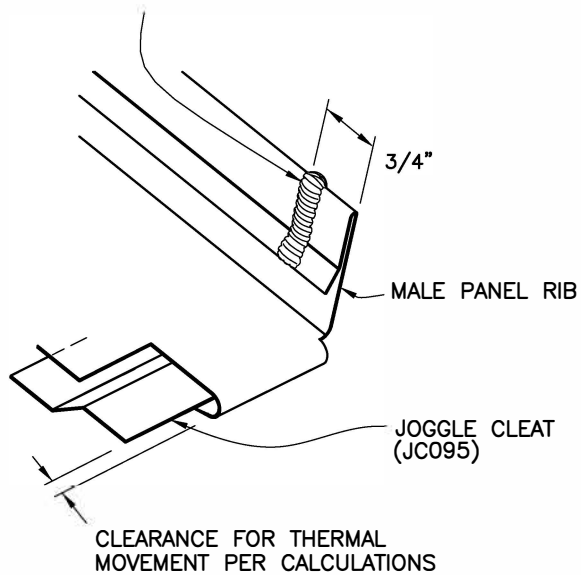

NOTE:
STANDARD FACTORY NOTCH IS 1-1/8". LONG LENGTH PANEL INSTALLATIONS REQUIRE GREATER FIELD NOTCHING DEPTH.



DESIGN SPAN HP



EAVE HEM

DS-05

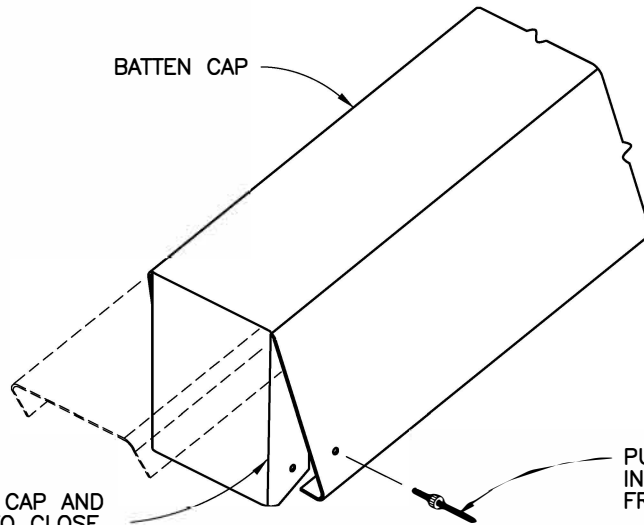

FIELD NOTCH CAP AND BEND OVER TO CLOSE OFF END OF BATTEN CAP.

PULL SIDES IN AND INSTALL 1/8" RIVET FROM EACH SIDE

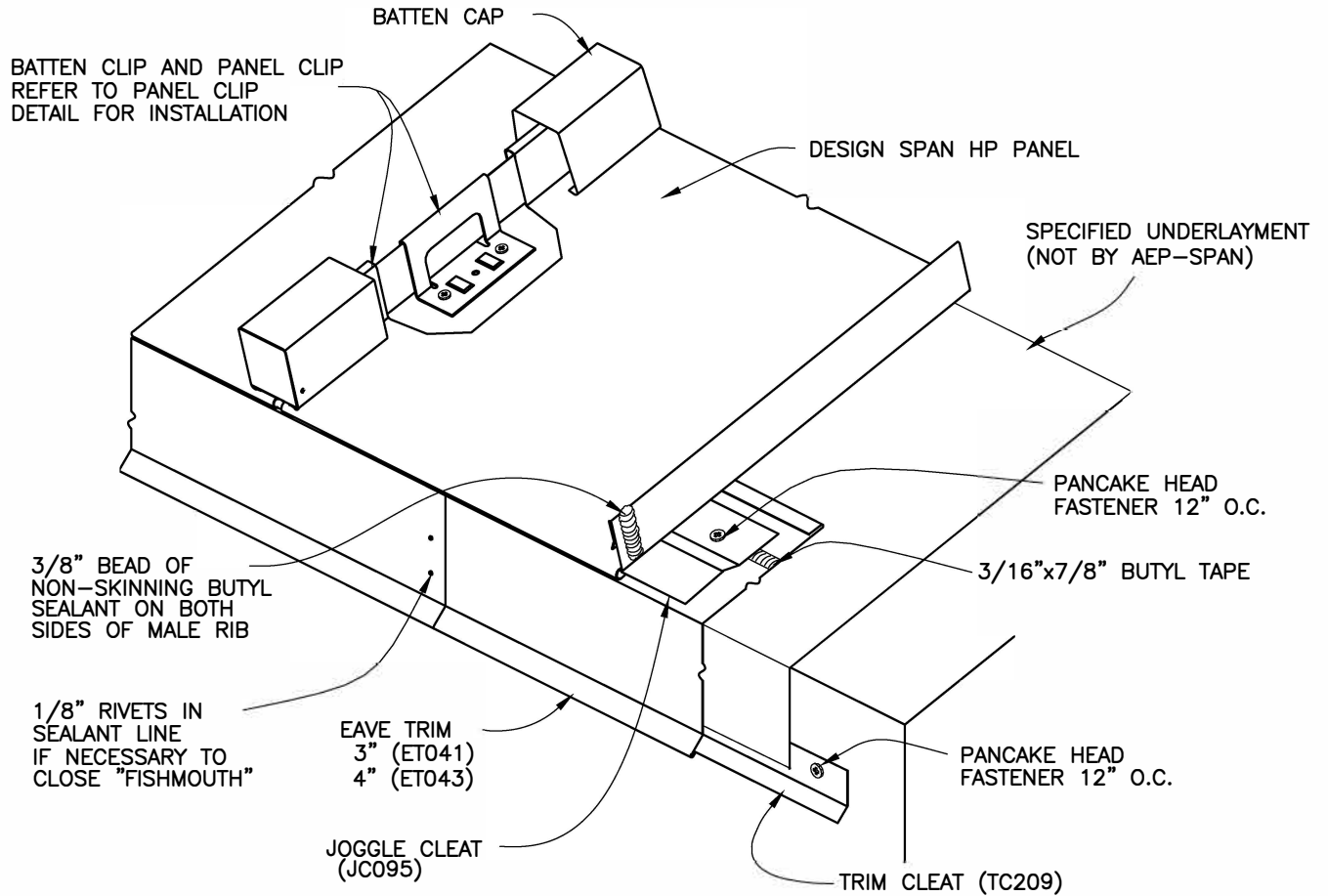

DESIGN SPAN HP



EAVE (WIDE BATTEN)

DS-06

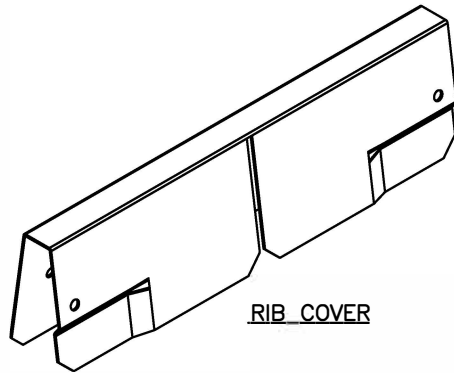

APPLY CURING SEALANT TO BOTH SIDES OF RIB PRIOR TO INSTALLING RIB COVER

RIB COVER

PANEL CLIP

DESIGN SPAN HP PANEL

DESIGN CAUTION:
 ROOF SLOPE TRANSITIONS SUCH AS FASCIAS MAY ESTABLISH AN UNWANTED POINT OF PANEL FIXITY. CONTACT YOUR AEP SPAN REPRESENTATIVE FOR ASSISTANCE.

1/8" RIVET BOTH SIDES

FIELD CUT PANEL RIBS AND BEND OVER EDGE. SEAL OPEN ENDS OF ROOF PANEL RIBS WITH CURING SEALANT BEFORE INSTALLING RIB COVER

DESIGN SPAN HP PANEL

SPECIFIED UNDERLAYMENT (NOT BY AEP-SPAN)

PANEL CLIP (CONTACT AEP-SPAN FOR CLIP LOCATION & SPACING)

SUBSTRATE

PANCAKE HEAD FASTENERS

1/4" MIN. CLEARANCE FOR WEEPAGE

FIELD NOTCH AND HEM 1" (OPTIONAL FACTORY PANEL NOTCH)

DRIP FLASHING (DF009)

SHOULD BE MINIMUM 1/4" GREATER THAN PANEL RIB HEIGHT.

NOTE:
 THE USE OF THIS DETAIL IS NOT RECOMMENDED IN SNOW CLIMATES.



DESIGN SPAN HP

FASCIA TRANSITION / WALL



DS-07

DESIGN CAUTION:
 ROOF SLOPE TRANSITIONS SUCH
 AS FASCIAS MAY ESTABLISH AN
 UNWANTED POINT OF PANEL
 FIXITY. CONTACT YOUR AEP SPAN
 REPRESENTATIVE FOR ASSISTANCE.

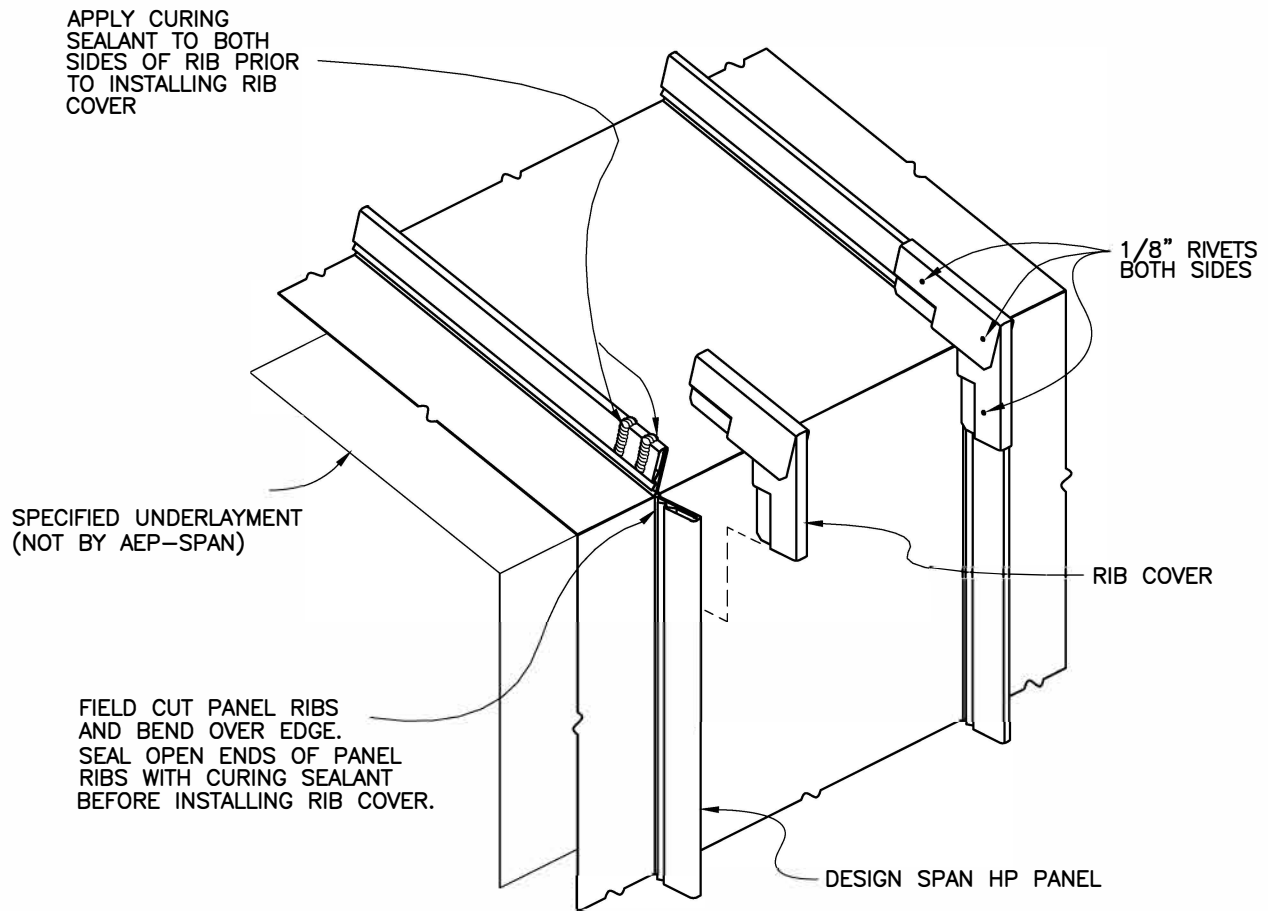

NOTE:
 THE USE OF THIS DETAIL IS NOT
 RECOMMENDED IN SNOW CLIMATES.



DESIGN SPAN HP

FASCIA TRANSITION



DS-08

FIELD CUT SIDES OF BATTEN CAP. NOTCH BOTTOM LEGS OF UPPER PORTION OF BATTEN CAP AS REQUIRED (VARIES PER ROOF SLOPE). BEND LOWER PORTION OF BATTEN CAP INTO PLACE. FASTEN IN PLACE WITH 1/8" RIVETS, BOTH SIDES.

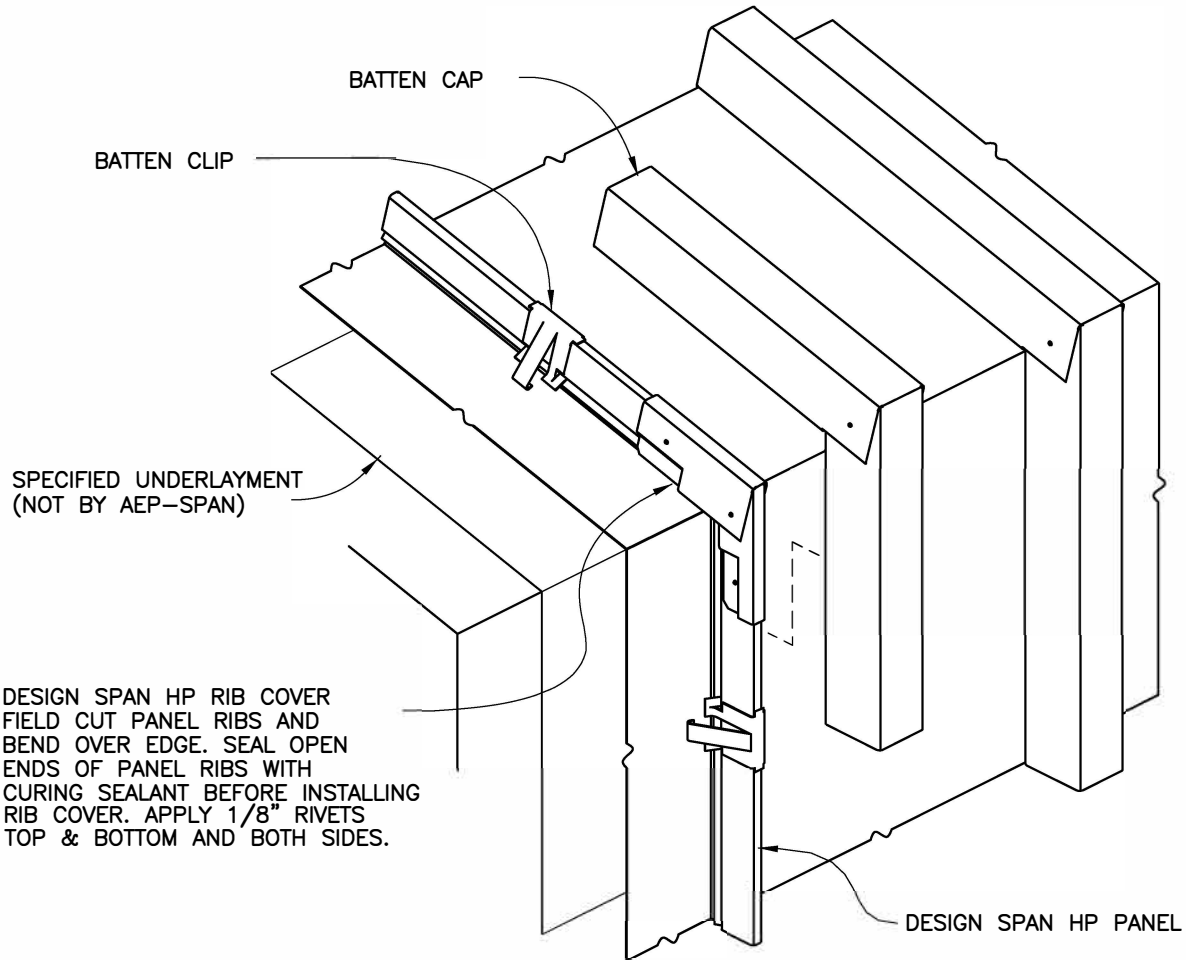
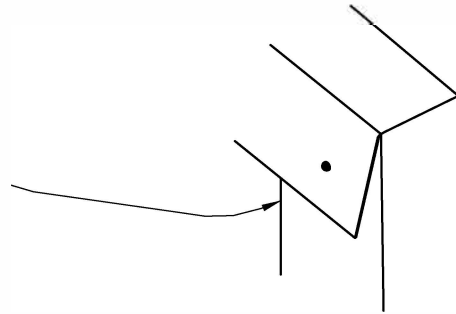

DESIGN SPAN HP RIB COVER
FIELD CUT PANEL RIBS AND
BEND OVER EDGE. SEAL OPEN
ENDS OF PANEL RIBS WITH
CURING SEALANT BEFORE INSTALLING
RIB COVER. APPLY 1/8" RIVETS
TOP & BOTTOM AND BOTH SIDES.

DESIGN CAUTION:
ROOF SLOPE TRANSITIONS SUCH
AS FASCIAS MAY ESTABLISH AN
UNWANTED POINT OF PANEL
FIXITY. CONTACT YOUR AEP SPAN
REPRESENTATIVE FOR ASSISTANCE.



DESIGN SPAN HP



FASCIA TRANSITION
(WIDE BATTEN)

DS-09

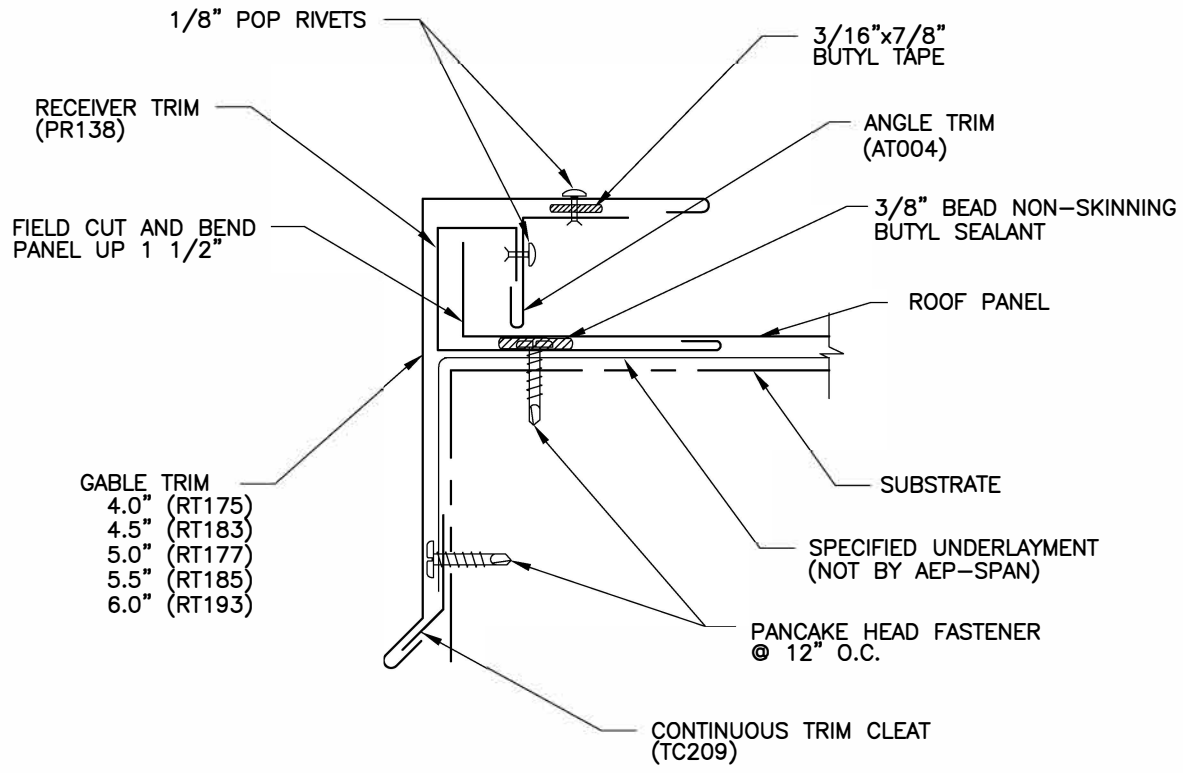

NOTE:
FIELD CUT FIRST AND
LAST PANELS TO
EQUAL WIDTH

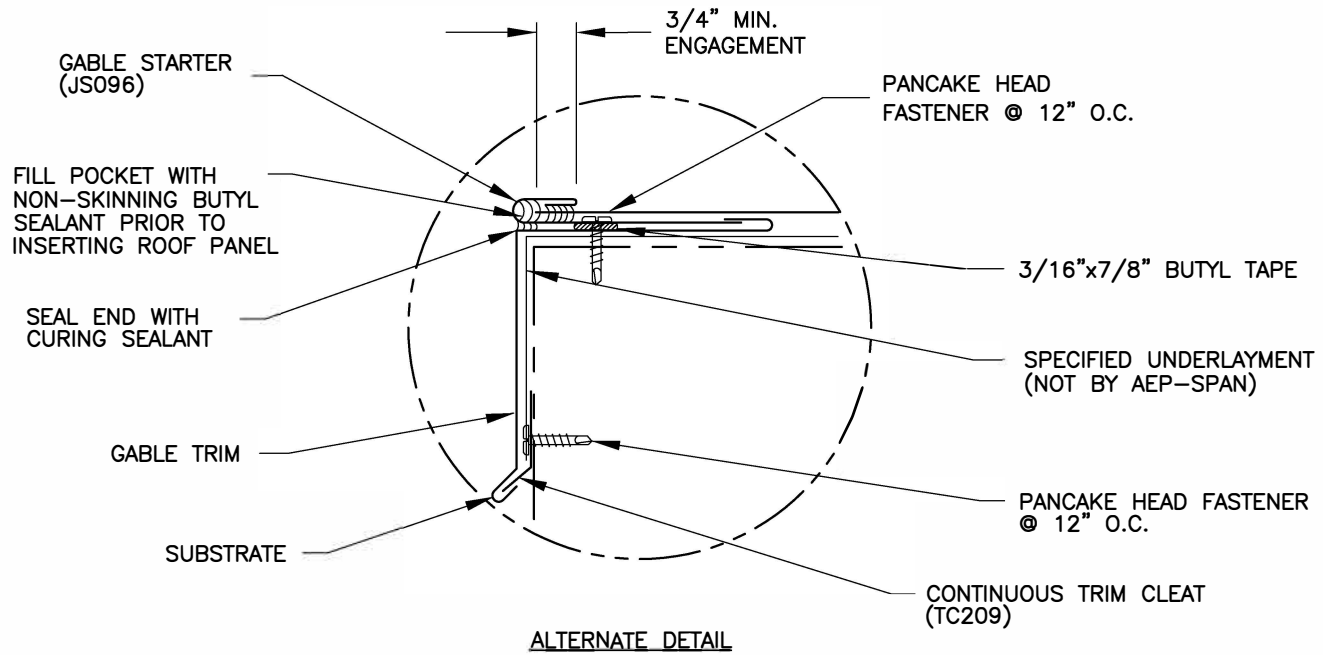

DESIGN SPAN HP

GABLE

DS-10

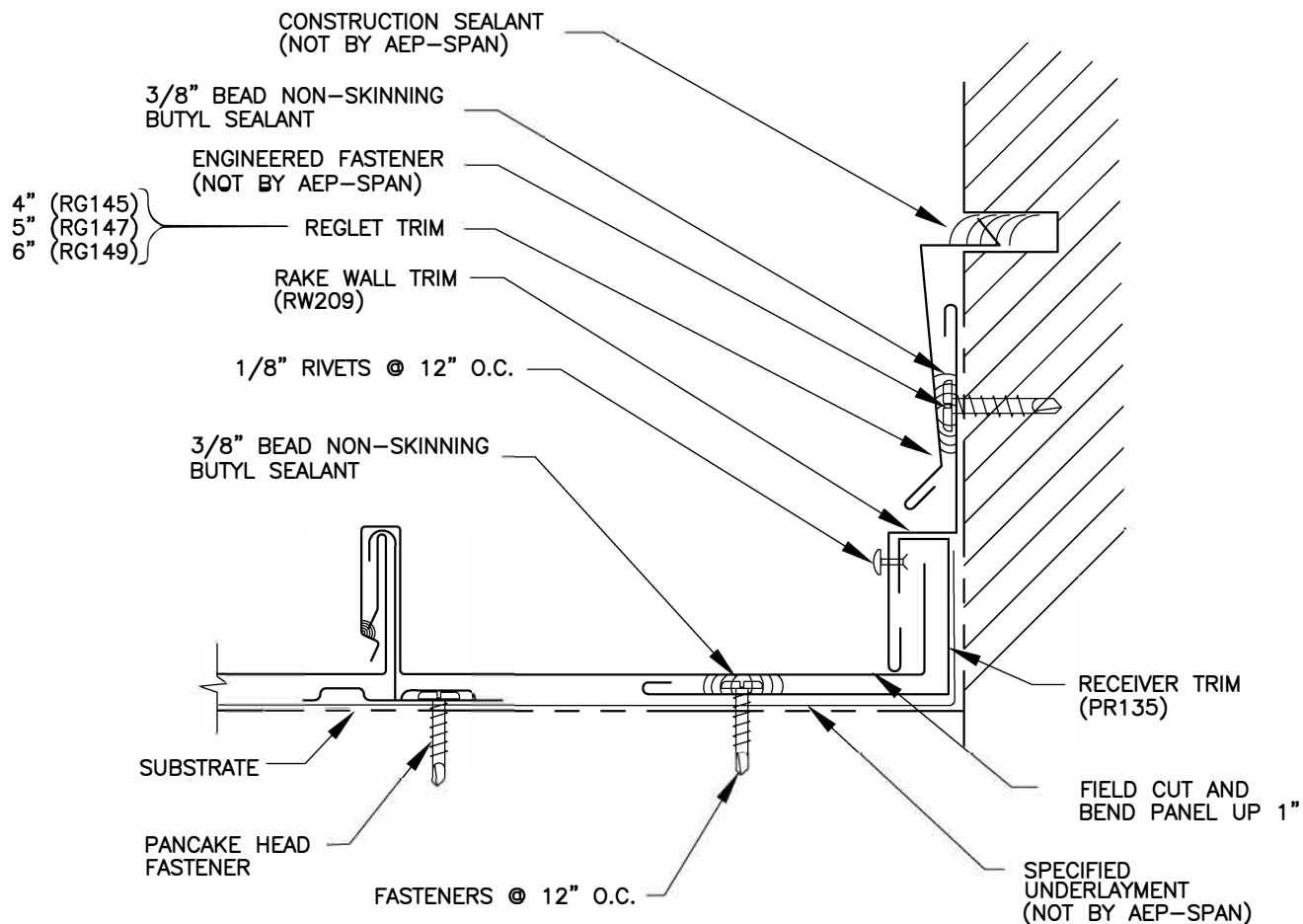
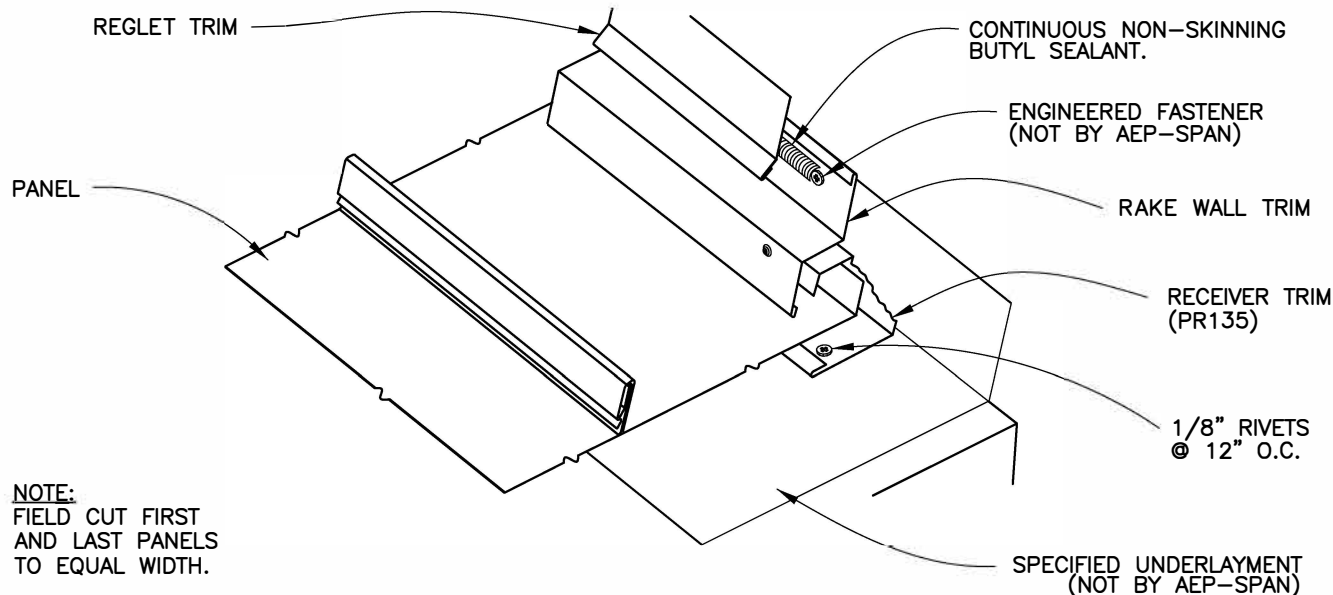

DESIGN SPAN HP

SIDE WALL
(RAKE WALL)

DS-11

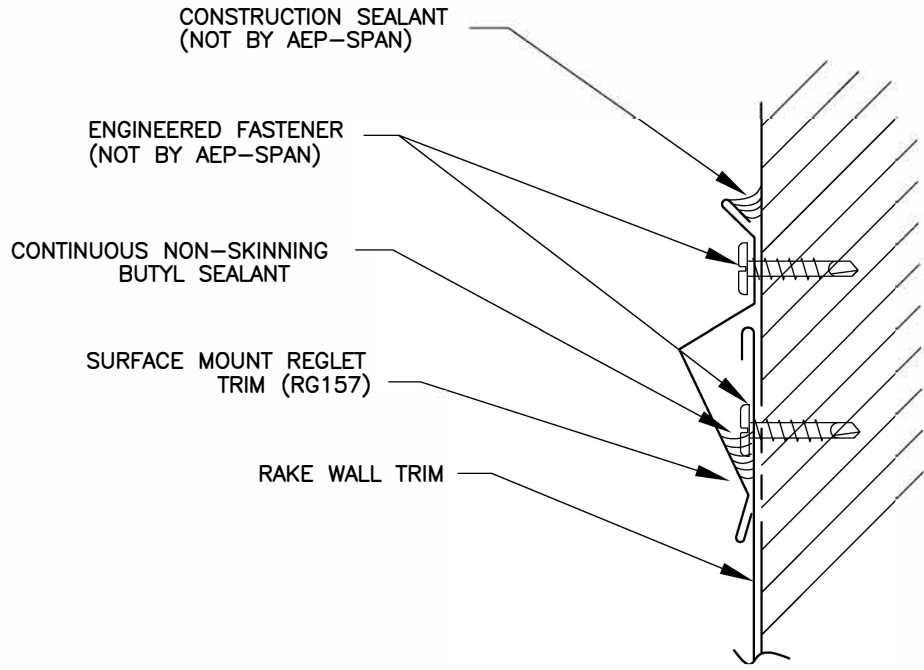

ALTERNATE UPPER DETAIL

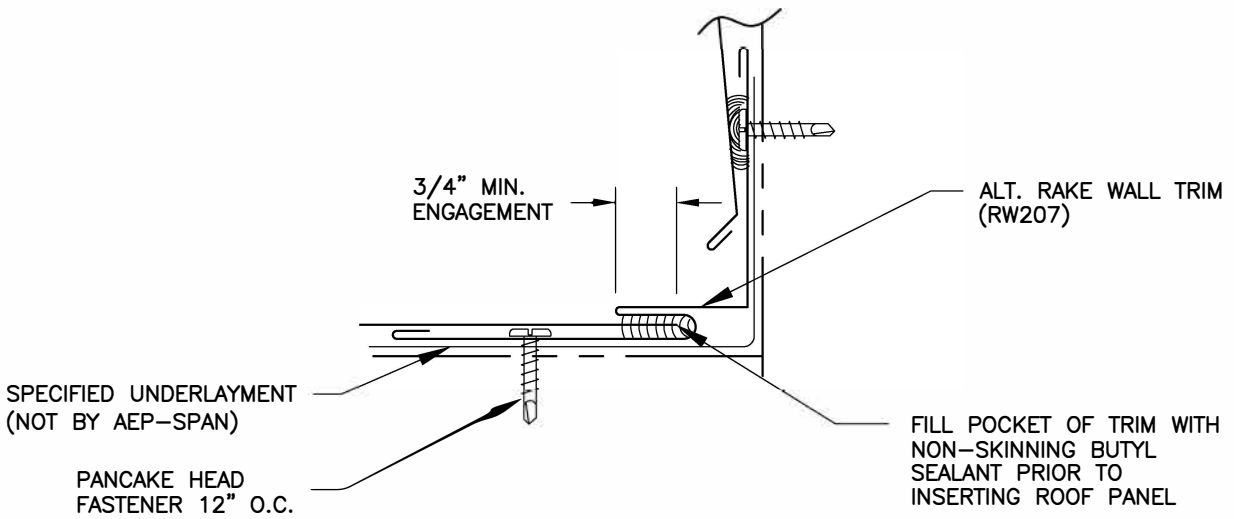

ALTERNATE LOWER DETAIL



DESIGN SPAN HP



SIDE WALL
(ALT. DETAILS)

DS-12

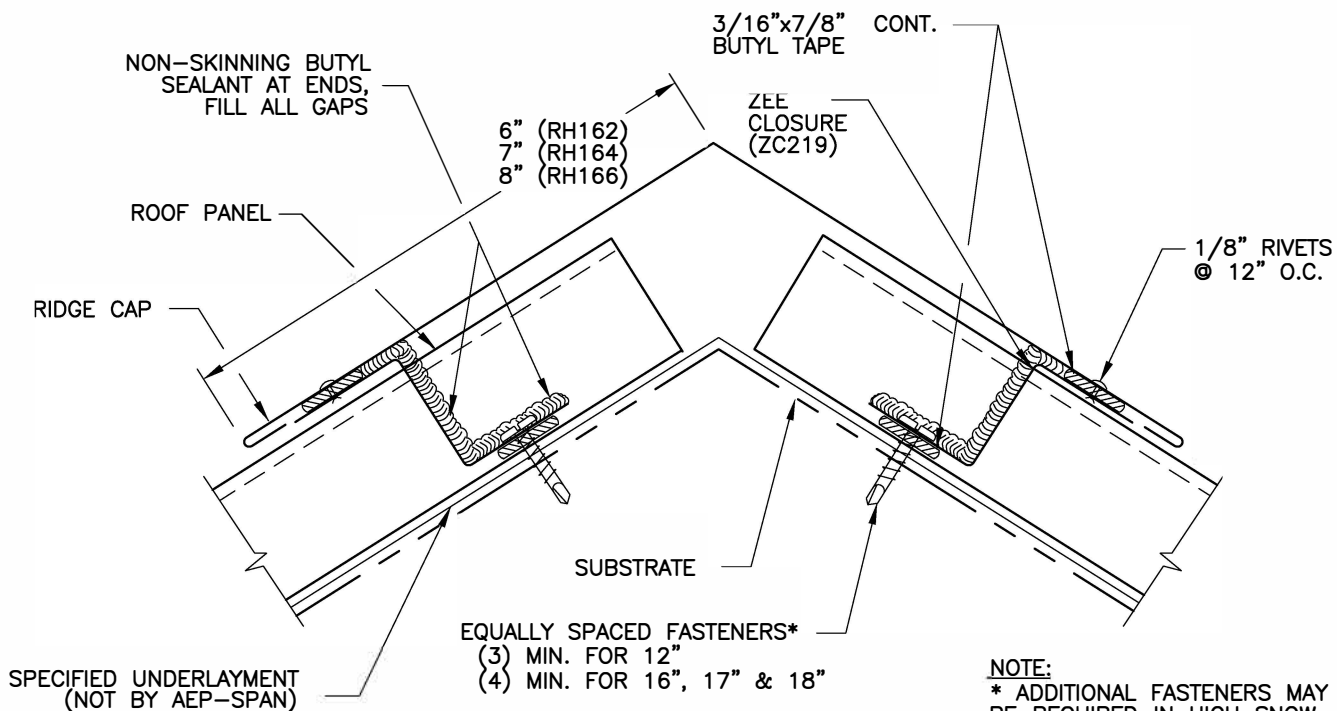
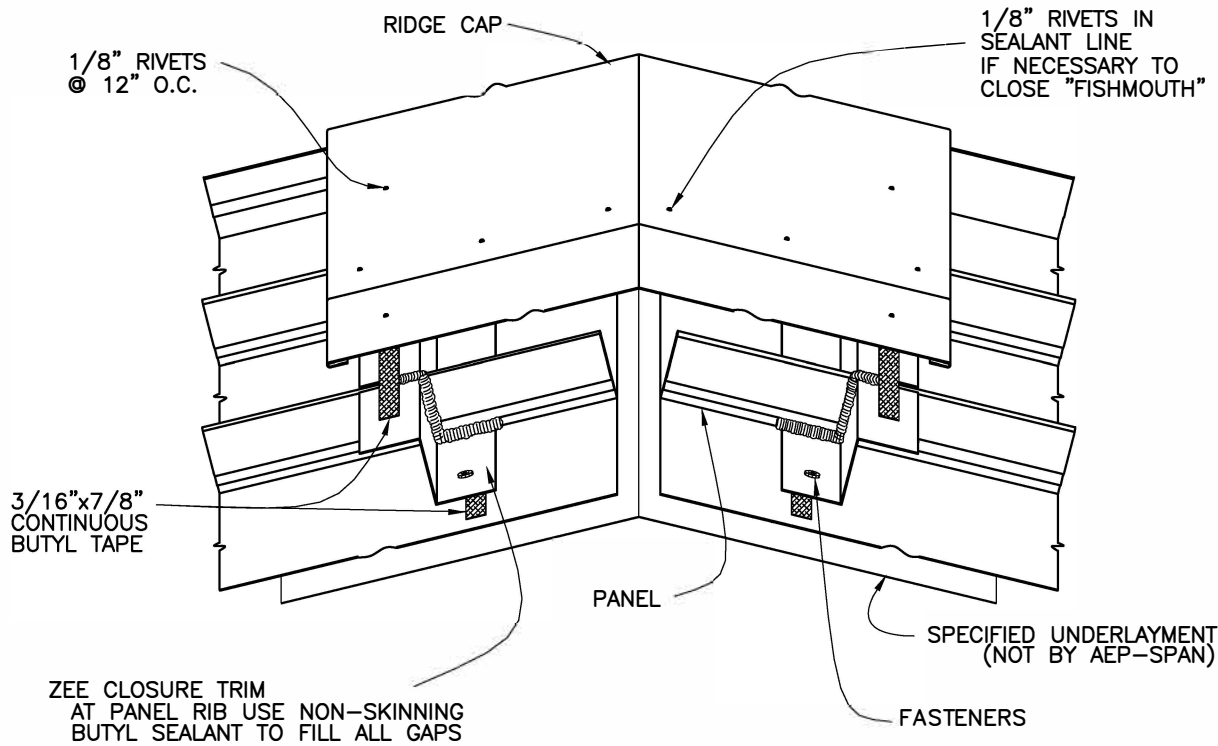

DESIGN SPAN HP

RIDGE / HIP



DS-13

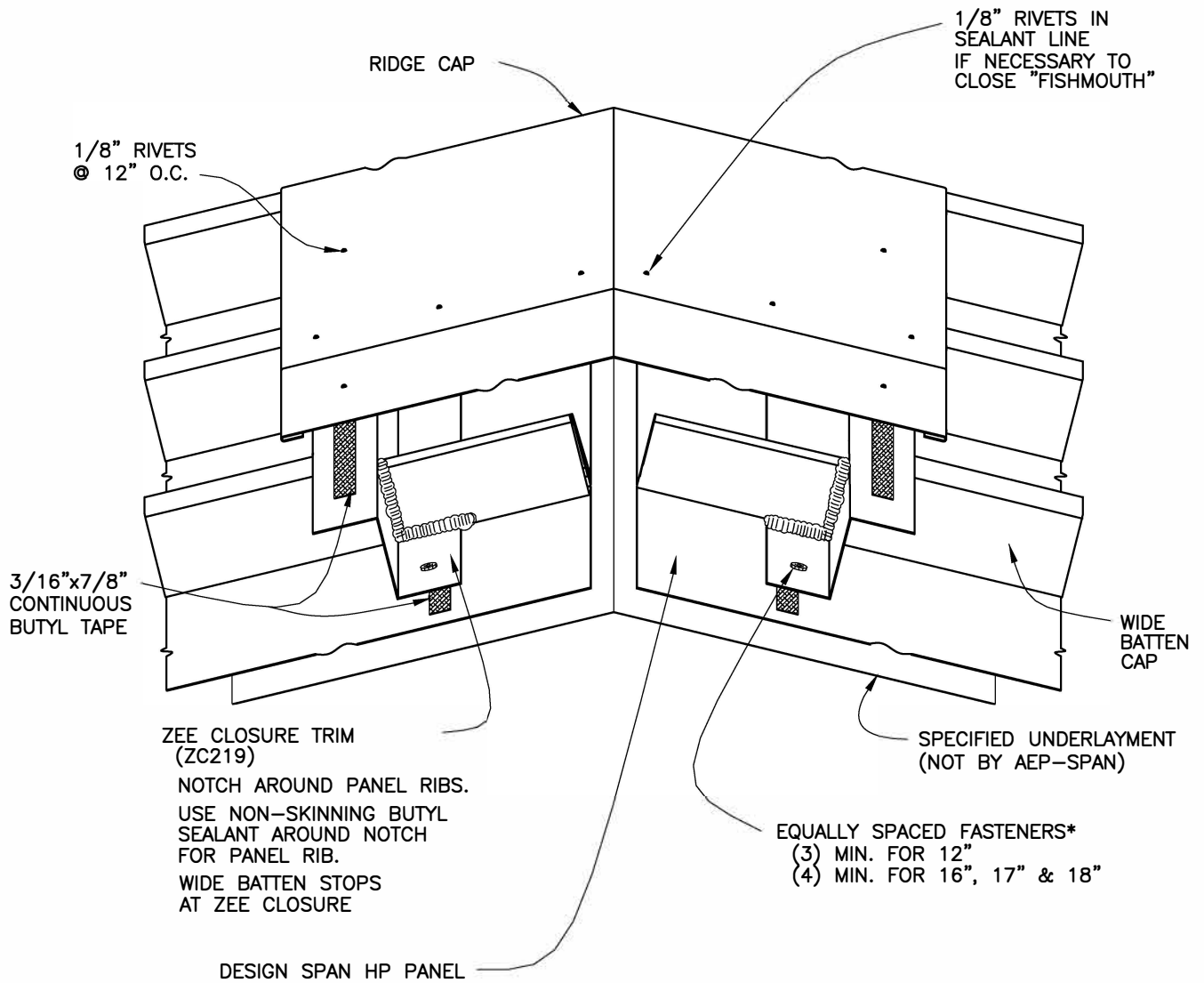

NOTE:
* ADDITIONAL FASTENERS MAY BE REQUIRED IN HIGH SNOW LOAD AREAS. SEE APPENDIX.



DESIGN SPAN HP

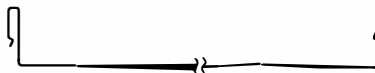

RIDGE / HIP
(WIDE BATTEN)

DS-14

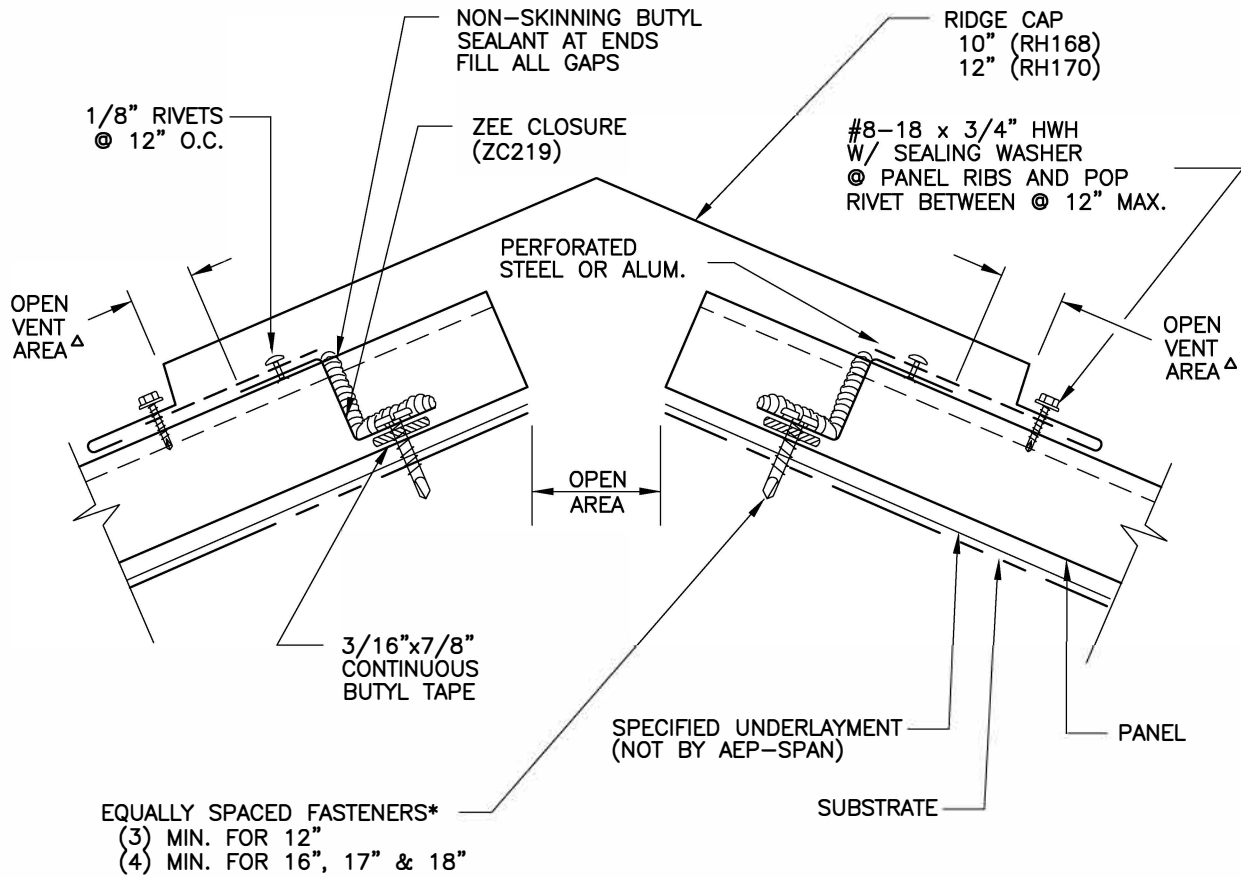

NOTES:

- Δ CUSTOMER MUST PROVIDE VENT AREA REQUIREMENTS
- * ADDITIONAL FASTENERS MAY BE REQUIRED IN HIGH SNOW LOAD AREAS. SEE APPENDIX.



DESIGN SPAN HP



RIDGE - VENTED

DS-15

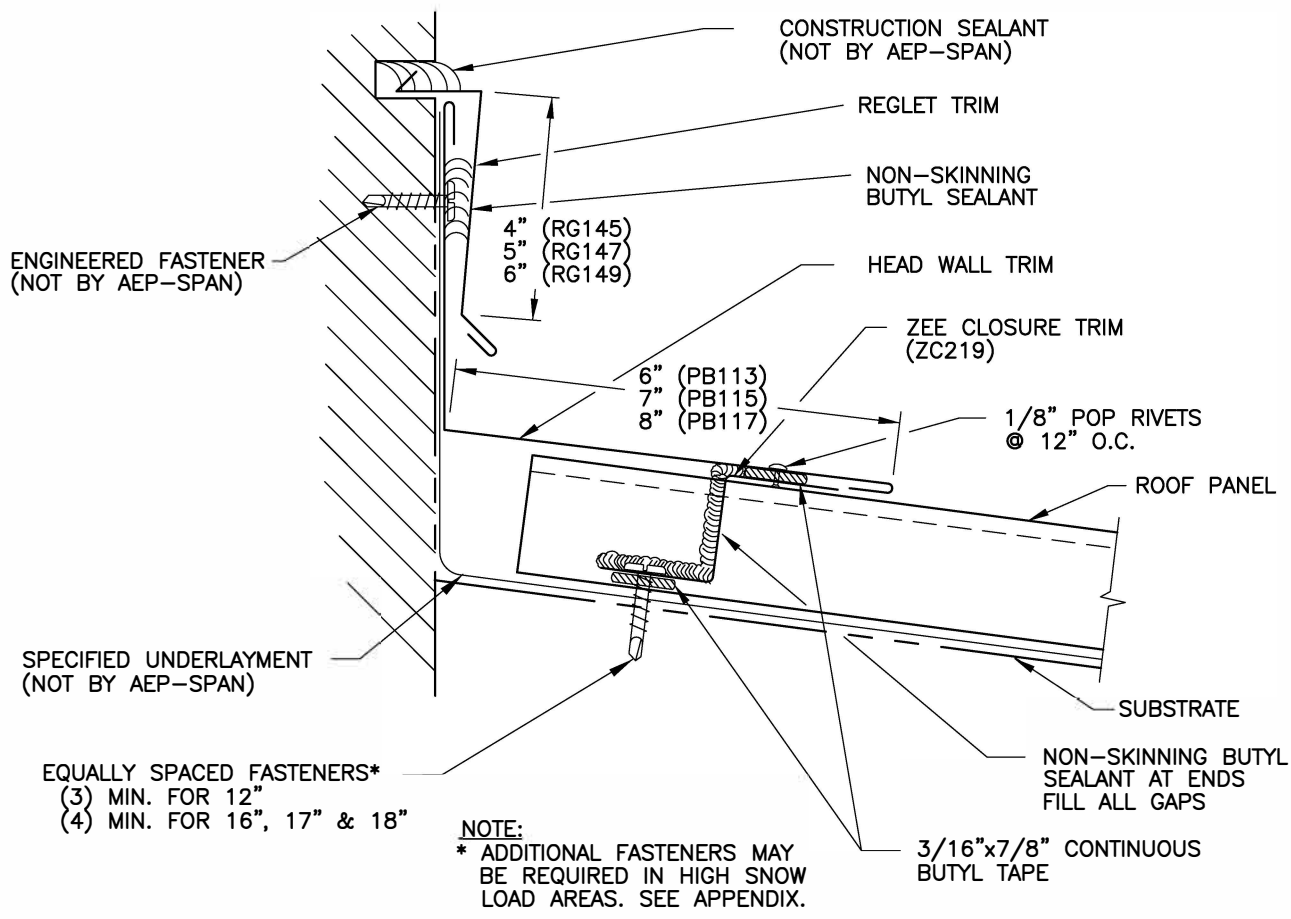
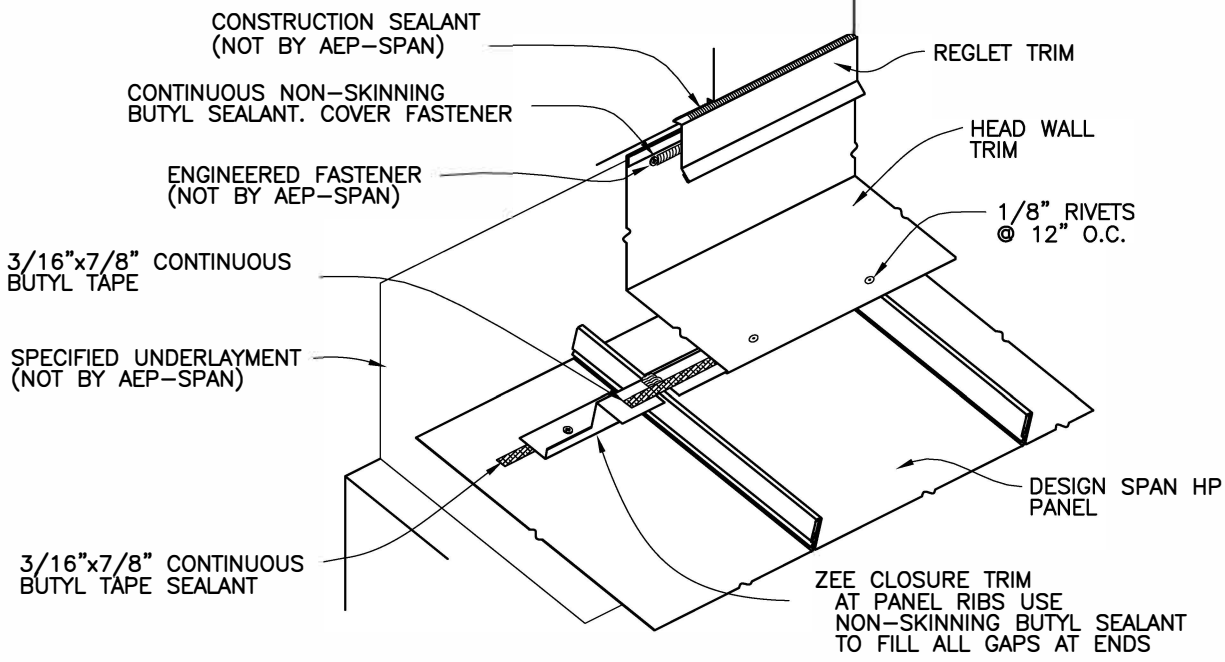

DESIGN SPAN HP

HEAD WALL



DS-16

1/8" RIVETS IN SEALANT LINE IF NECESSARY TO CLOSE "FISHMOUTH"

1/8" RIVETS SPACED 12" O.C. MAX.

3/16"x7/8" CONTINUOUS BUTYL TAPE

DESIGN SPAN HP PANEL

ZEE CLOSURE TRIM

HIGH EAVE TRIM

NON-SKINNING BUTYL SEALANT AT ENDS FILL ALL GAPS

3/16"x7/8" CONTINUOUS BUTYL TAPE

SPECIFIED UNDERLAYMENT (NOT BY AEP-SPAN)

EQUALLY SPACED FASTENERS*
(3) MIN. FOR 12"
(4) MIN. FOR 16", 17" & 18"

PANCAKE HEAD FASTENER 12" O.C.

TRIM CLEAT

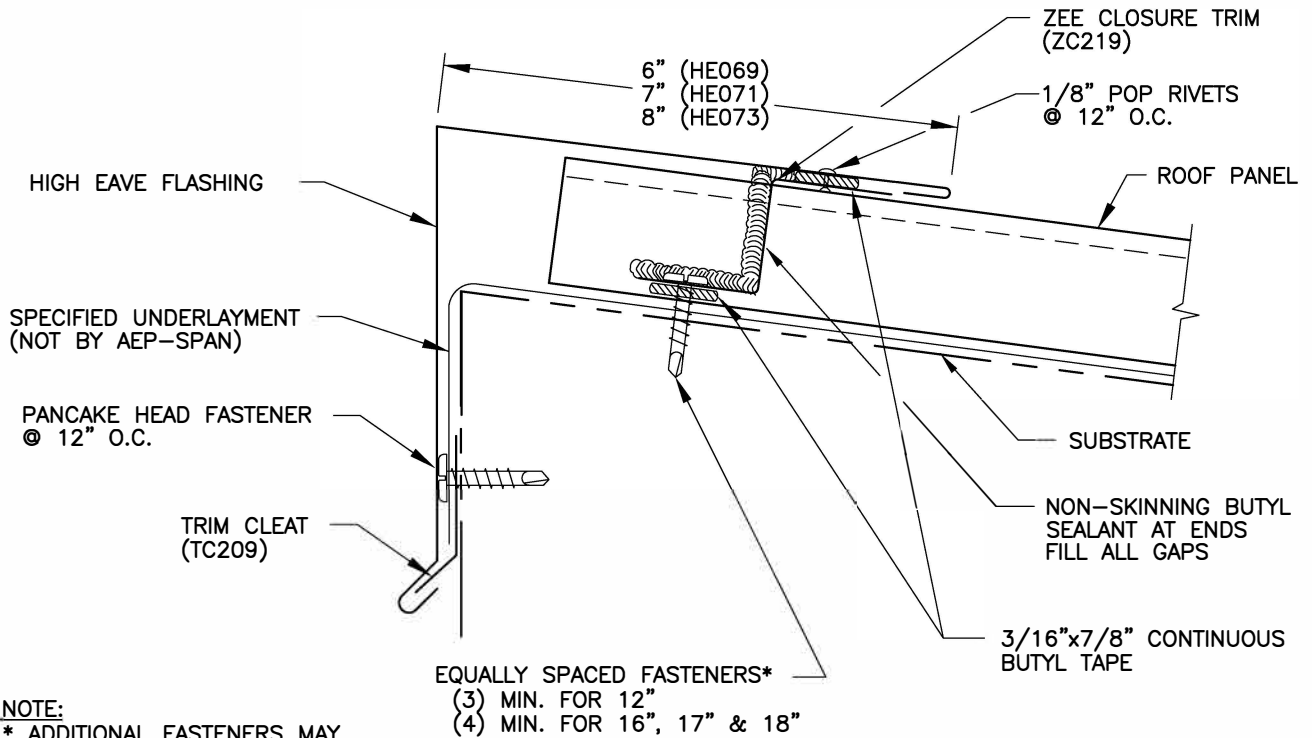

NOTE:

* ADDITIONAL FASTENERS MAY BE REQUIRED IN HIGH SNOW LOAD AREAS. SEE APPENDIX.



DESIGN SPAN HP

EAVE - HIGH



DS-17

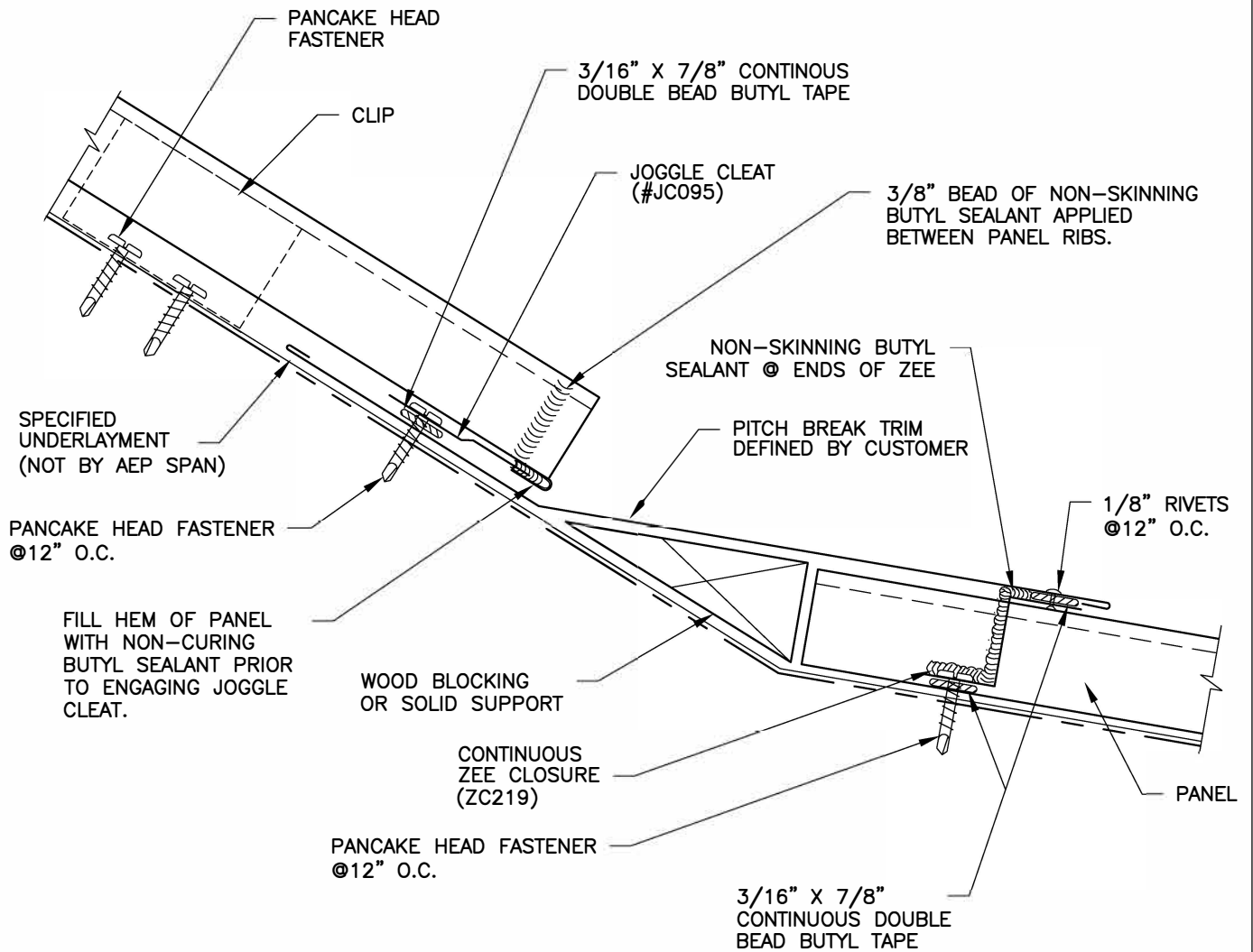

NOTE:
 REFER TO EAVE & RIDGE DETAILS FOR FURTHER INFORMATION ON PROPER PANEL TERMINATIONS.



DESIGN SPAN HP

SLOPE TRANSITION



DS-18

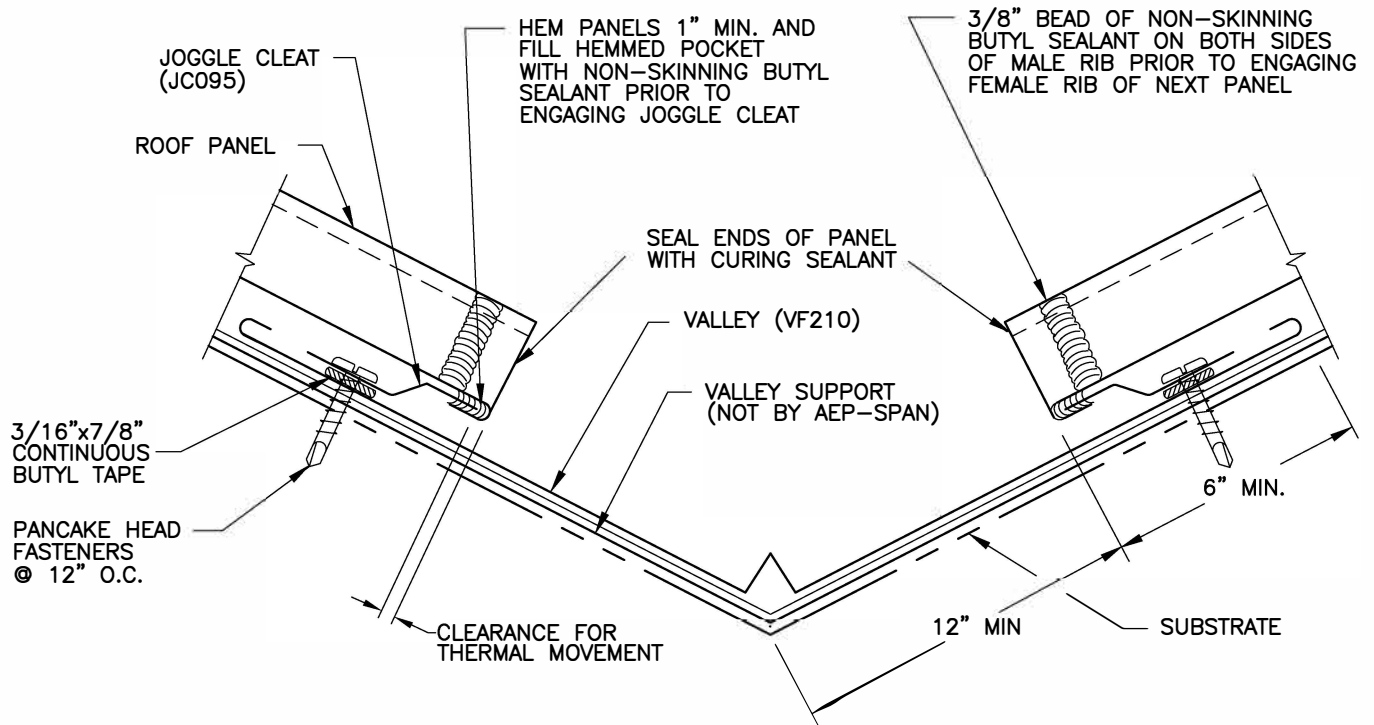
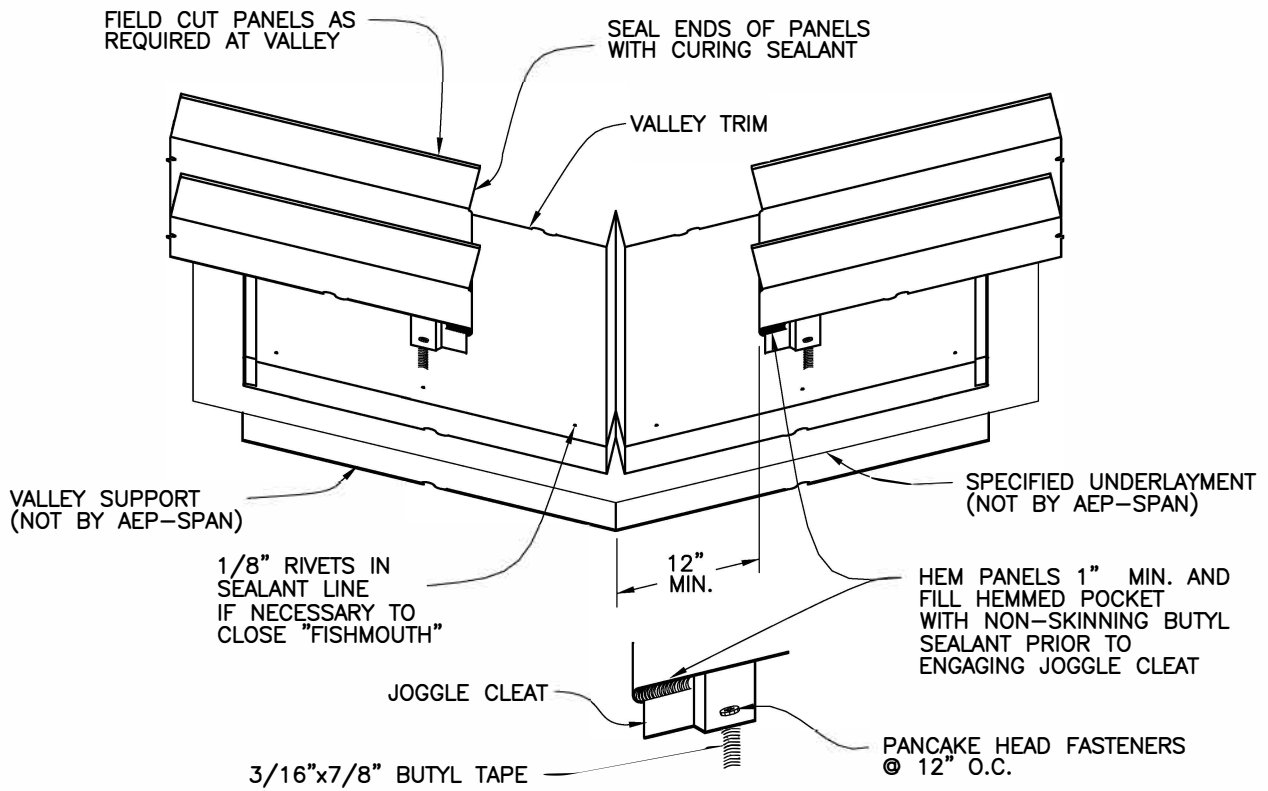

DESIGN SPAN HP

VALLEY



DS-19

ROOF JACK

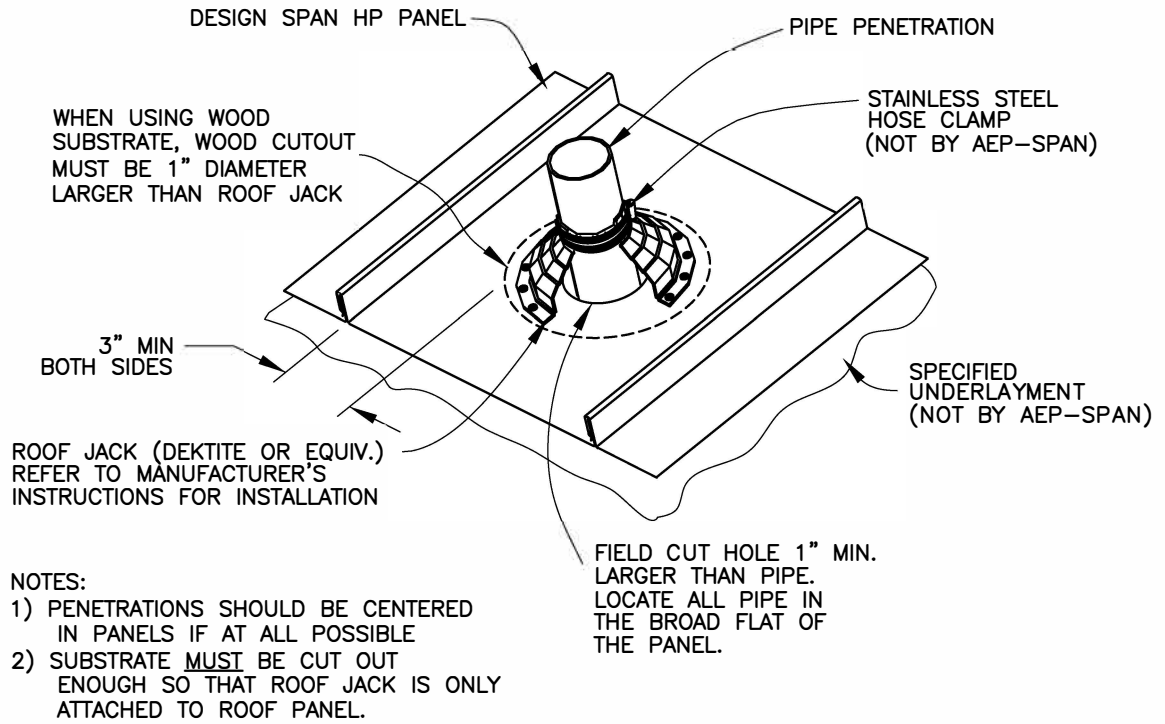

ROOF CURB

CONTACT AEP SPAN REPRESENTATIVE IF ADDITIONAL ROOF PENETRATION INFORMATION IS REQUIRED.

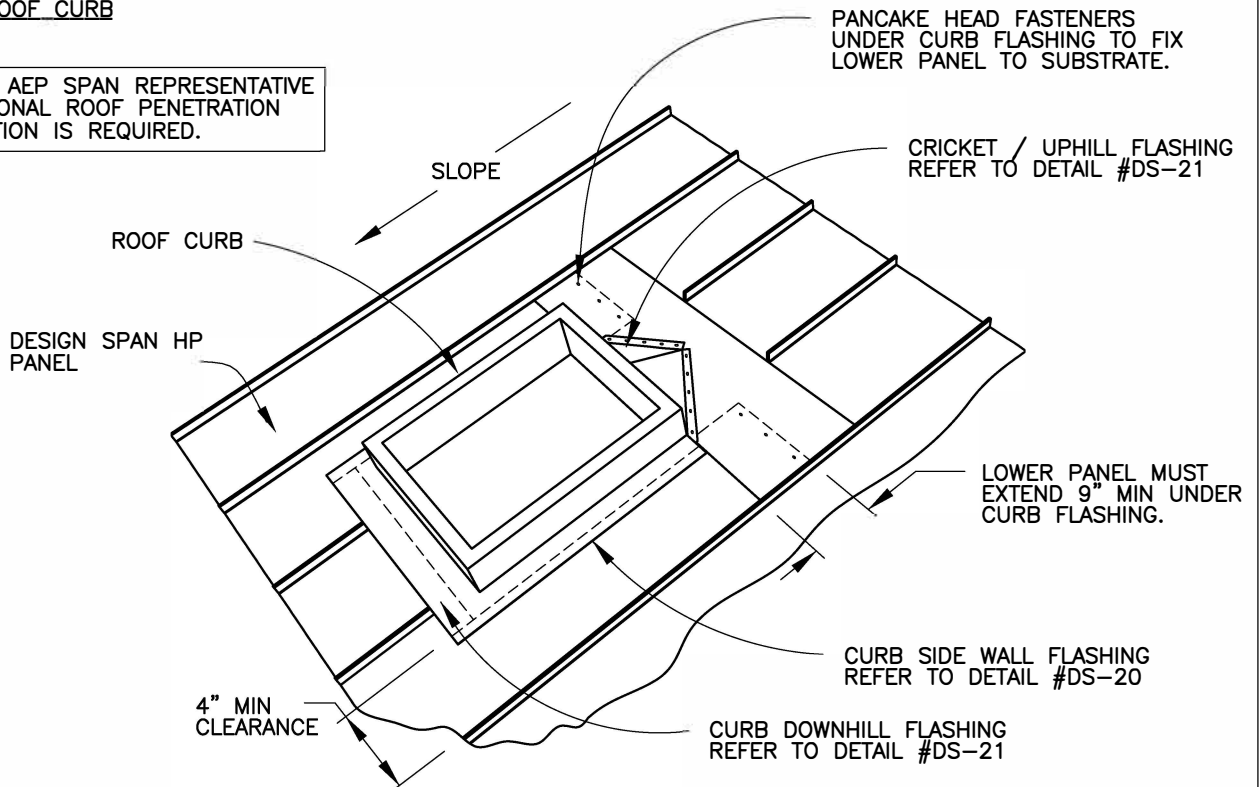

DESIGN SPAN HP

ROOF PENETRATIONS



DS-20

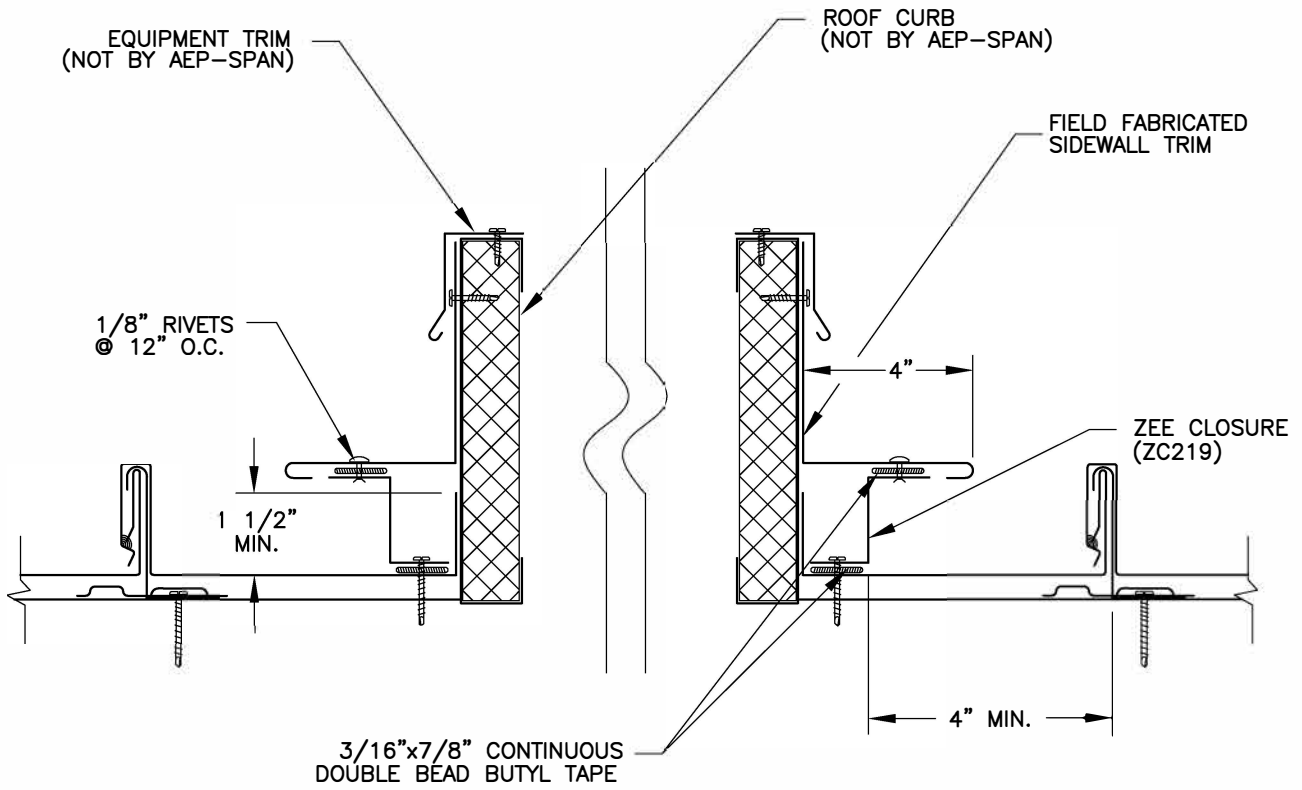

DESIGN SPAN HP



ROOF CURB
(SIDE WALL FLASHING)

DS-21

FIELD FABRICATE CURB
FLASHINGS FROM FLAT SHEET

CONTACT AEP SPAN REPRESENTATIVE
IF ADDITIONAL ROOF PENETRATION
INFORMATION IS REQUIRED.

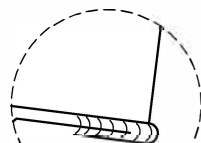
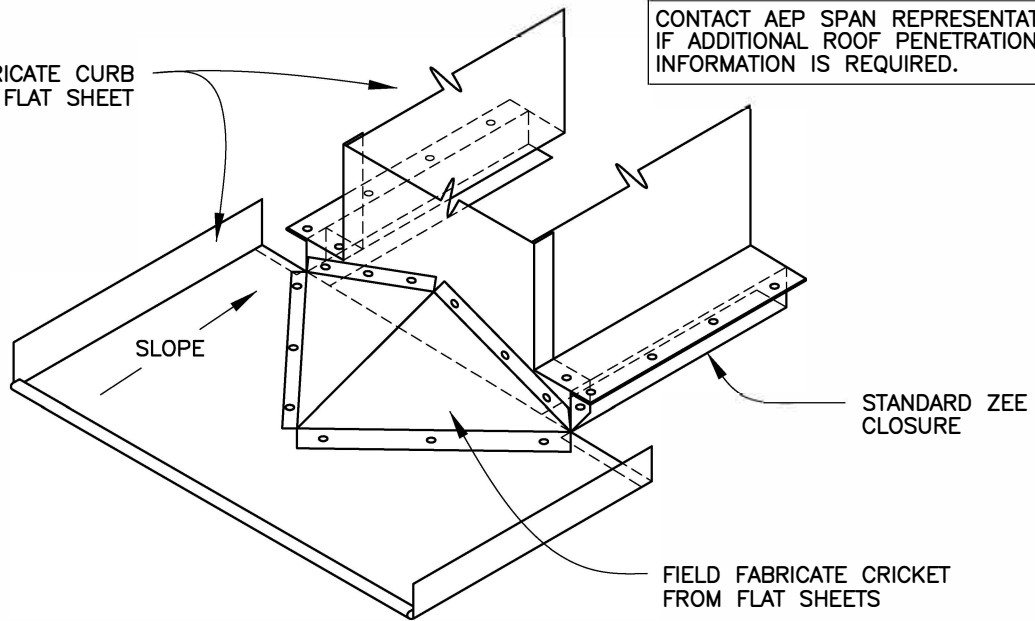

EQUIPMENT TRIM
(NOT BY AEP-SPAN)

CLEARANCE FOR
THERMAL MOVEMENT
PER CALCULATIONS

FASTENER
(NOT BY AEP-SPAN)

CRICKET TO BE
FIELD FABRICATED
FROM FLAT STOCK

FIELD FABRICATED
HEADWALL TRIM

1/8" RIVET
@ 12" O.C.

FASTENER
(NOT BY AEP-SPAN)

8" MIN

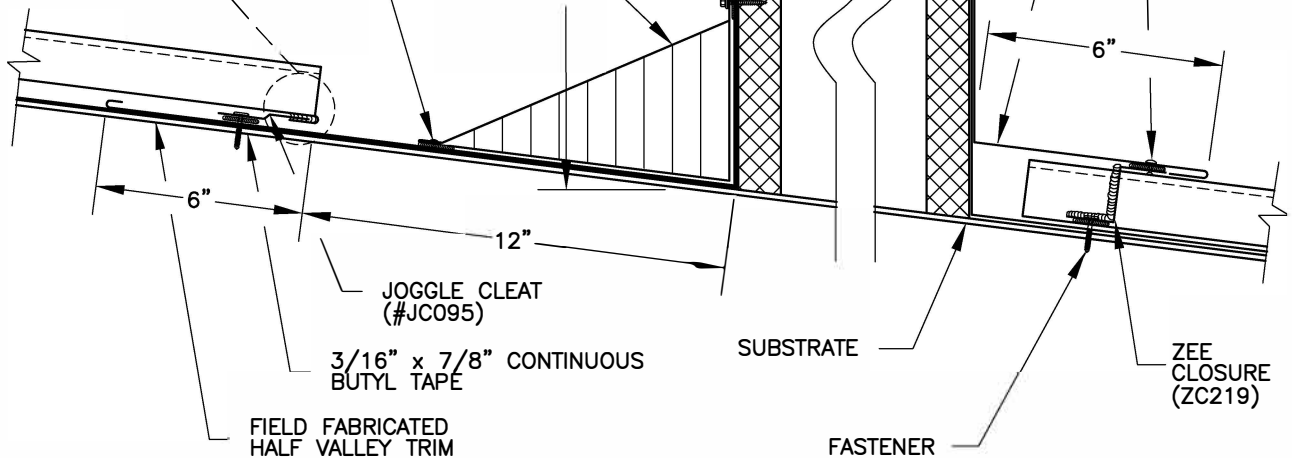

NOTE:
CURBS 24" WIDE OR GREATER REQUIRE USE OF CRICKETS.
CRICKETS OPTIONAL ON NARROWER CURBS.



DESIGN SPAN HP



ROOF CURB (UPHILL /
DOWNHILL DETAIL)

DS-22

Appendix A: Snow Drag Loads (lbs/ft of panel)

12" Design Span hp

Slope	Ground Snow Load, P_g (psf)								
	25	30	35	40	45	50	55	60	65
2:12	5.0	5.9	7.0	8.0	9.0	9.9	10.9	12.0	12.9
3:12	7.4	8.8	10.3	11.7	13.2	14.6	16.1	17.7	19.1
4:12	9.6	11.5	13.4	15.2	17.2	19.1	21.1	23.0	24.9
5:12	11.6	13.9	16.3	18.6	20.9	23.2	25.7	28.0	30.3
6:12	13.6	16.2	19.0	21.7	24.3	27.1	29.8	32.4	35.2
7:12	15.2	18.3	21.3	24.4	27.5	30.5	33.5	36.5	39.7
8:12	16.8	20.1	23.5	26.9	30.3	33.5	36.9	40.3	43.7
9:12	18.2	21.8	25.4	29.0	32.7	36.3	39.9	43.6	47.2
10:12	19.4	23.2	27.1	31.0	34.8	38.7	42.6	46.5	50.3
11:12	20.4	24.6	28.7	32.7	36.8	40.9	45.0	49.0	53.1
12:12	21.4	25.7	29.9	34.2	38.5	42.8	47.1	51.3	55.7

16" Design Span hp

Slope	Ground Snow Load, P_g (psf)								
	25	30	35	40	45	50	55	60	65
2:12	6.7	8.0	9.3	10.6	12.0	13.3	14.6	16.0	17.2
3:12	9.8	11.7	13.7	15.6	17.7	19.6	21.5	23.5	25.4
4:12	12.7	15.2	17.9	20.4	23.0	25.5	28.1	30.6	33.2
5:12	15.5	18.6	21.7	24.8	28.0	31.0	34.1	37.3	40.3
6:12	18.0	21.7	25.3	28.9	32.4	36.1	39.7	43.3	46.9
7:12	20.3	24.4	28.4	32.5	36.5	40.7	44.8	48.8	52.9
8:12	22.4	26.9	31.3	35.8	40.3	44.8	49.2	53.7	58.2
9:12	24.2	29.0	33.9	38.7	43.6	48.4	53.2	58.1	62.9
10:12	25.8	31.0	36.2	41.3	46.5	51.7	56.7	62.0	67.2
11:12	27.2	32.7	38.1	43.6	49.0	54.5	60.0	65.5	70.9
12:12	28.6	34.2	39.9	45.6	51.3	57.0	62.8	68.5	74.2

Notes:

- To determine drag load forces per panel, multiply the tabulated value by the panel length. Then refer to Appendix B for fastener schedule.
- Values assume Ground Snow Load (P_g) is provided. Drag Loads may be reduced if actual Roof Snow Loads (E_s), per ASCE-7, are provided by customer.
- For roof slopes and snow loads greater than listed above, please contact your AEP Span representative.

Appendix A: Snow Drag Loads (lbs/ft of panel)

17" Design Span hp

Slope	Ground Snow Load, P_g (psf)								
	25	30	35	40	45	50	55	60	65
2:12	7.0	8.5	9.9	11.3	12.7	14.0	15.5	16.9	18.3
3:12	10.4	12.5	14.5	16.6	18.8	20.8	22.9	24.9	27.0
4:12	13.6	16.2	19.0	21.7	24.4	27.1	29.8	32.5	35.2
5:12	16.5	19.7	23.1	26.4	29.6	32.9	36.3	39.6	42.8
6:12	19.1	23.0	26.9	30.6	34.5	38.4	42.1	46.0	49.9
7:12	21.5	25.9	30.3	34.6	38.8	43.2	47.6	51.8	56.1
8:12	23.7	28.6	33.3	38.0	42.8	47.6	52.3	57.0	61.8
9:12	25.8	30.9	36.1	41.1	46.3	51.4	56.6	61.7	66.9
10:12	27.5	32.9	38.4	43.9	49.4	54.8	60.4	65.8	71.4
11:12	28.9	34.7	40.5	46.3	52.2	58.0	63.8	69.5	75.3
12:12	30.3	36.4	42.5	48.5	54.6	60.6	66.7	72.7	78.8

18" Design Span hp

Slope	Ground Snow Load, P_g (psf)								
	25	30	35	40	45	50	55	60	65
2:12	7.5	9.0	10.4	12.0	13.4	14.9	16.5	17.9	19.4
3:12	11.0	13.2	15.4	17.7	19.8	22.0	24.2	26.4	28.6
4:12	14.4	17.2	20.1	23.0	25.8	28.7	31.6	34.5	37.3
5:12	17.4	20.9	24.4	28.0	31.5	34.8	38.4	41.9	45.4
6:12	20.3	24.3	28.4	32.4	36.5	40.5	44.6	48.6	52.8
7:12	22.9	27.5	32.1	36.5	41.1	45.7	50.3	54.8	59.4
8:12	25.2	30.3	35.2	40.3	45.3	50.3	55.4	60.4	65.5
9:12	27.2	32.7	38.1	43.6	49.0	54.5	59.9	65.3	70.8
10:12	29.0	34.8	40.7	46.5	52.3	58.1	63.9	69.7	75.5
11:12	30.6	36.8	43.0	49.0	55.2	61.3	67.4	73.6	79.7
12:12	32.1	38.5	44.9	51.3	57.7	64.1	70.5	77.0	83.4

Notes:

- To determine drag load forces per panel, multiply the tabulated value by the panel length. Then refer to Appendix B for fastener schedule.
- Values assume Ground Snow Load (P_g) is provided. Drag Loads may be reduced if actual Roof Snow Loads (E_s), per ASCE-7, are provided by customer.
- For roof slopes and snow loads greater than listed above, please contact your AEP Span representative.

Appendix B:

Drag Load Resistance

Fastener Type	Substrate	Capacity (lbs)	Number of Fasteners per Panel								
			2	3	4	5	6	7	8	9	10
#12-14 x 1" SD HWH	16ga Steel min.	234	468	702	936	1170	1404	1638	1872	2106	2340
1/4-14 x 7/8" Lap SD HWH	22ga Steel min.	184	368	552	736	920	1104	1288	1472	1656	1840
#14 x 1" Type A Mill. Point HWH	1/2" Plywood min.	128	256	384	512	640	768	896	1024	1152	1280
#14 x 1" Type A Mill. Point HWH	2x Douglas Fir	57	114	171	228	285	342	399	456	513	570
#10-16 x 1" SD Pancake Head	16ga Steel min.	206	412	618	824	1030	1236	1442	1648	1854	2060
#10-16 x 1" SD Pancake Head	22ga Steel min.	154	308	462	616	770	924	1078	1232	1386	1540
#10-12 x 1" Type A Pancake Head	1/2" Plywood min.	108	216	324	432	540	648	756	864	972	1080
#10-12 x 1" Type A Pancake Head	2x Douglas Fir	54	108	162	216	270	324	378	432	486	540

Example:

16" Design Span hp attached to 1/2" plywood.

4:12 slope

30psf snow load

40ft maximum panel length

#10-12 pancake head fasteners used

a) From Appendix A, find the drag load per linear foot of panels: 4:12 & 30psf snow load = 15.2 lbs/ft

b) Multiply the load by the panel length = 15.2lbs/ft X 40ft = 608lbs drag load per panel.

c) Find the drag load in Appendix B.

The nearest value is 648 lbs for Qty=6, #10-12 x 1" type A pancake head fasteners.

Notes:

- Contact your AEP Span representative if there are any questions regarding the use of these appendices.
- Fasteners must be located a minimum of 1" from each other and from the end of the panel.

MANUFACTURING FACILITY:

Tacoma, Washington

2141 Milwaukee Way
Tacoma, WA 98421

CORPORATE HEADQUARTERS:

ASC Profiles LLC

2110 Enterprise Boulevard
West Sacramento, CA 95691

CUSTOMER SERVICE:

800-733-4955

Visit us at:

www.aepspan.com

