

Miscellaneous Details

<u>Contents</u>	<u>Section</u>
Accessory Drawings	
Roof Curb (Plan View)	AC-1
Roof Curb (Rake)	AC-2
Roof Curb (Section)	AC-3
Roof Jack (Dektite).....	AC-4
Expansion Joint.....	AC-5
Vented Ridge.....	AC-6
Pitch Break.....	AC-7
Recommended Sealants	AC-13

↙ SLOPE DOWN

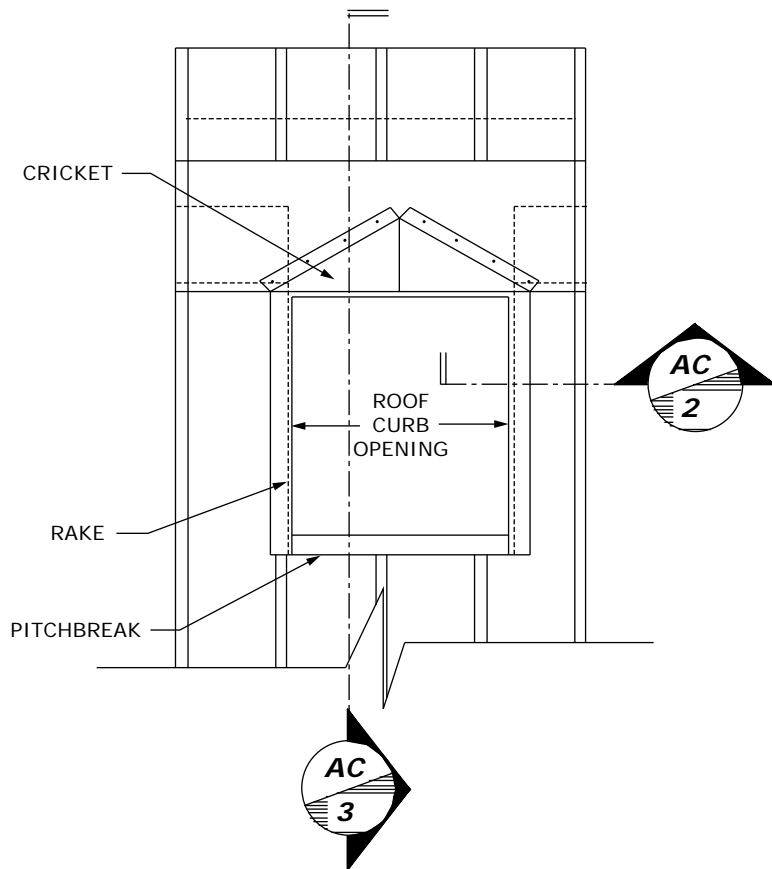

ACCESSORIES

ROOF CURB PLAN VIEW

AC-1

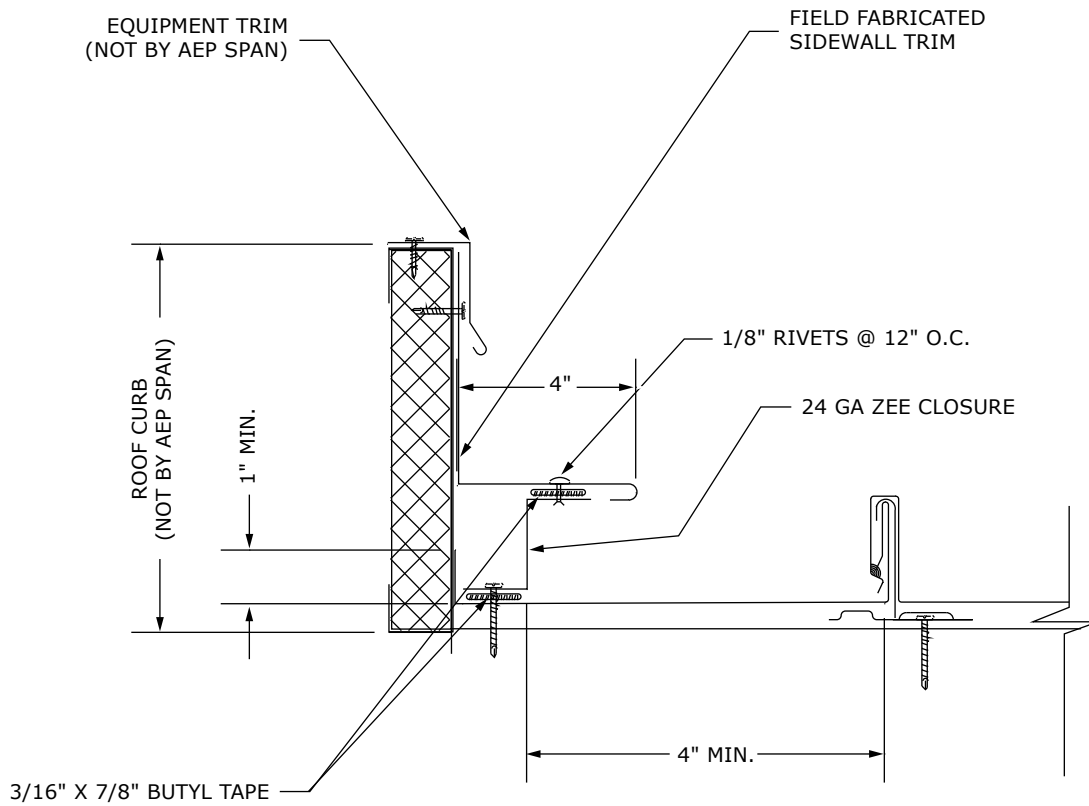

ACCESSORIES

ROOF CURB RAKE

AC-2

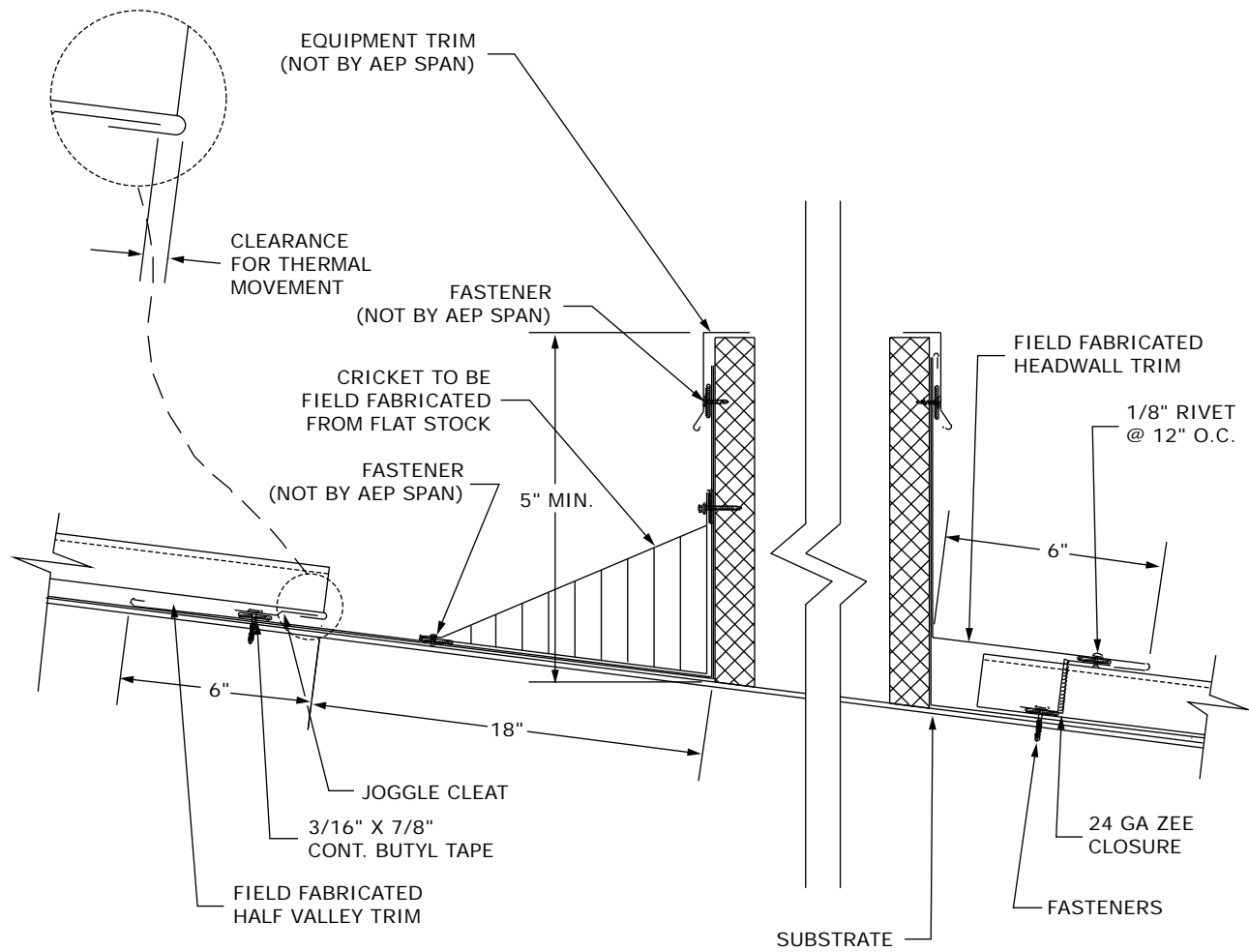

ACCESSORIES

ROOF CURB SECTION

AC-3

NOTES:

- 1) PENETRATIONS SHOULD BE CENTERED IN PANELS IF AT ALL POSSIBLE.
- 2) SUBSTRATE MUST BE CUT OUT ENOUGH SO THAT DEKTITE IS ONLY ATTACHED TO ROOF PANEL.

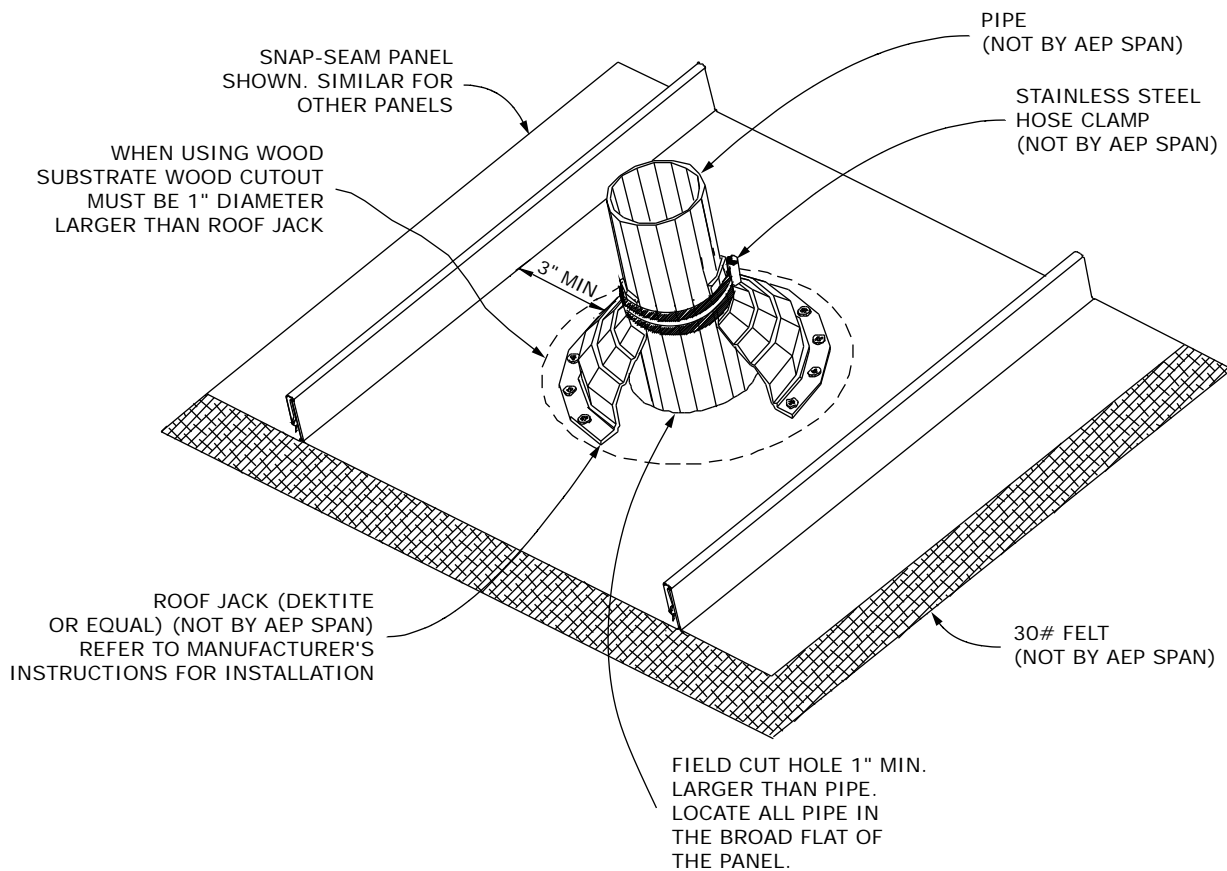

ACCESSORIES

ROOF JACK (DEKTITE)

AC-4

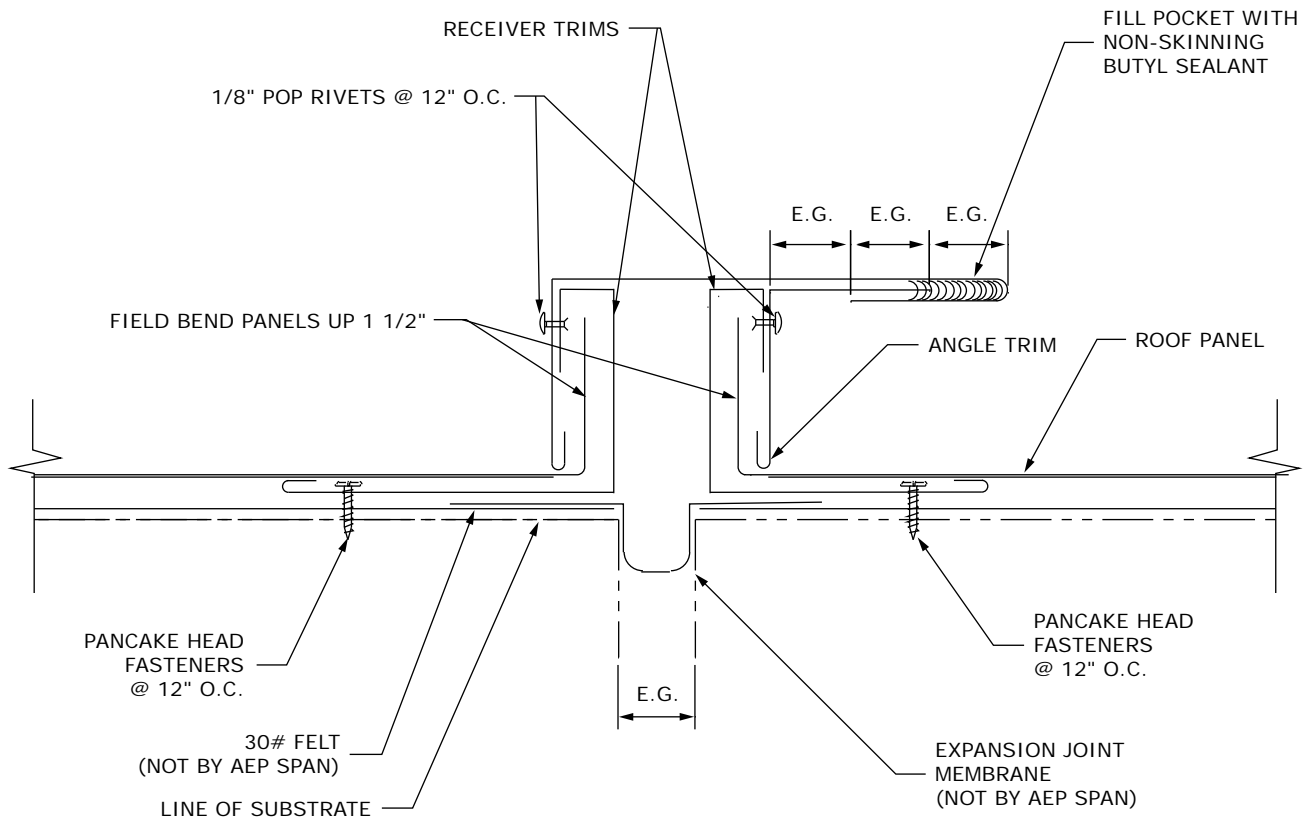

NOTES:
 E.G. = EXPANSION GAP
 FOR EVEN RIB SPACING PANELS MAY
 NEED TO BE CUT AND FIELD BENT UP
 1 1/2" TO FIT INTO RECEIVER TRIM.



ACCESSORIES

EXPANSION JOINT

AC-5

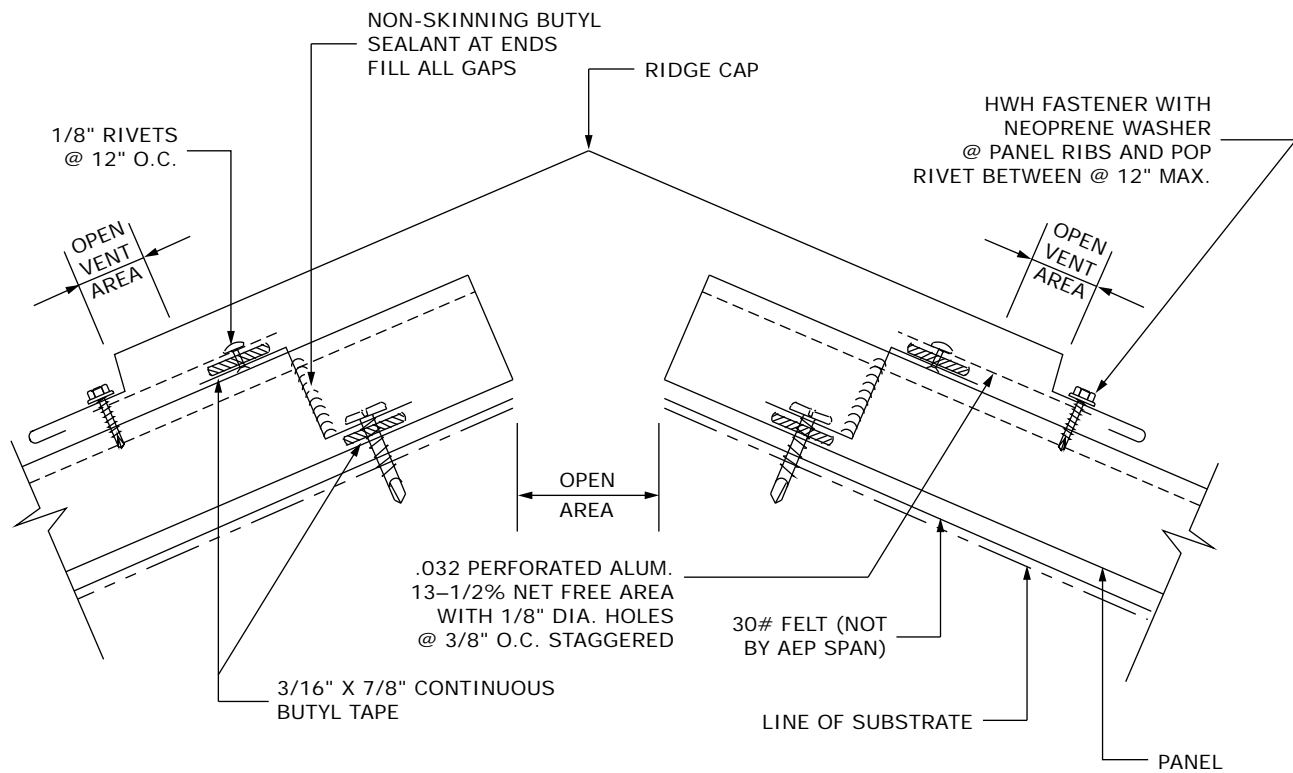

NOTE:
CUSTOMER MUST PROVIDE
VENT AREA REQUIREMENTS



ACCESSORIES

VENTED RIDGE

AC-6

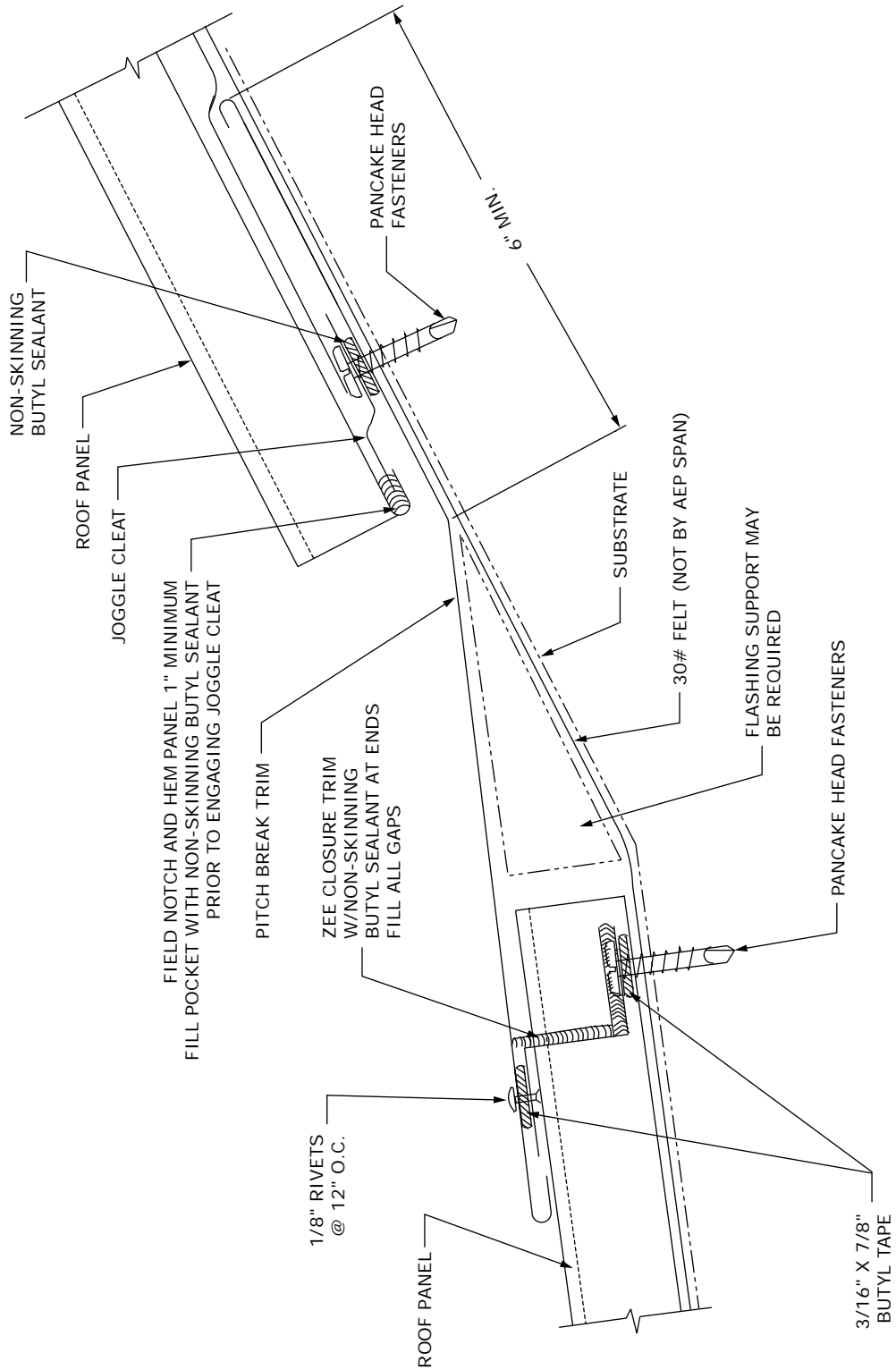

ACCESSORIES

PITCH BREAK

AC-7