



Reversed Box Rib™ Installation Guide

Table of Contents

General

Notes	i - ii
Panel details	1

Roof Installation Details

Eave	4
Eave with Gutter	5
Gutter, Post-Hung	6
Gable	7
Valley	8
Ridge	9
Vented Ridge	10
Peak	11

Vertical Wall Installation Details

Base	20
Sill	21
Endwall	22
Outside Corner	23
Inside Corner	24
Soffit, Front	25
Soffit, Back	26
Parapet	27
Door / Window (Head)	28

Horizontal Wall Installation Details

Base	38
Sill	39
Eave / Fascia	40
Endwall	41
Outside Corner	42
Inside Corner	43
Soffit, Front	44
Soffit, Back	45
Parapet	46

Fasteners	2
Sidewall	12
Endwall	13
Slope Transition - High to Low	14
Slope Transition - Low to High	15
Panel Lap	16
Roof Curb	17
Curb Flashings	18

Opening, Head (Nail Fin)	29
Door / Window (Jamb)	30
Opening, Jamb (Nail Fin)	31
Door / Window (Sill)	32
Opening, Sill (Nail Fin)	33
Penetration, 3D	34
Penetration, 2D	35
Penetration Examples	36

Door / Window (Head)	47
Opening, Head (Nail Fin)	48
Door / Window (Jamb)	49
Opening, Jamb (Nail Fin)	50
Door / Window (Sill)	51
Opening, Sill (Nail Fin)	52
Penetration, 3D	53
Penetration, 2D	54
Penetration Examples	55

GENERAL NOTES

The attached installation details are intended to be a design aid and do not depict all situations. Modifications are the responsibility of the designer/user and should consider climate conditions such as wind and snow, wildfire, governing code requirements, and the actual usage and maintenance of the structure.

Applications:

Reversed Box Rib is acceptable for use as a roofing panel and as a wall panel installed in the vertical or horizontal orientation. The recommended minimum slope for Reversed Box Rib is 1:12. Reversed Box Rib can be installed over solid substrates or over spaced supports. This installation guide depicts Box Rib installed over mixed substrates. It is the responsibility of the designer/user to make proper installation adjustments to address the installation conditions on the project.

Flashings:

Where feasible, flashings should be lapped away from prevailing winds. Certain flashings should be supported if it is likely that equipment (ladder, etc.) will be used against them. Check with AEP Span any time you intend to specify a prefinished flashing in a gauge or finish different than the Reversed Box Rib panels. It is good practice to specify that all flashings be of the same material (gauge, color, finish) as the roof & wall panels to ensure long-term durability. Painted flashings rarely equal the durability and colorfastness of factory baked-on paint systems. The enclosed details have minimized the use of exposed fasteners where possible. The edges of flashings have also been shown hemmed to strengthen and to minimize the exposure of cut edges.

Flashing design and fabrication is generally the responsibility of the contractor. For convenience, we have provided typical flashing drawings on our website. Applicable Reversed Box Rib flashing part numbers are referenced within this installation guide. Note that flashing shapes and dimensions may vary greatly based on project requirements. Installation details and flashings referenced within are for general design guidance only.

Condensation, Insulation, & Ventilation:

It is the designer's responsibility to determine the need and composition of moisture control materials including insulation and vapor retarders, as well as ventilation requirements. Metal roof and wall products are susceptible to condensation, and its control should be carefully considered.

For metal roofing panels, an underlayment should be installed over the roof substrate. AEP Span recommends using AEP Span Underlayment HT, which is specifically engineered for all AEP Span roofing systems and suitable for use under any metal roofing system or coping. AEP Span Underlayment HT is a high-temperature, self-healing, self-adhering, peel-and-stick underlayment with a non-abrasive surface that will not mar, scratch, or abrade the underside of metal panels and flashings. Please note that additional protection may be required to achieve Class A fire ratings as defined in UL 790 classified assemblies.

Thermal Movement:

Both panels and flashings must allow for thermal movement (expansion and contraction) of the materials, especially where long lengths are used. Appropriate gaps or provisions must be provided to accommodate thermal movement.

Designing for Snow:

If possible, valleys, gutters, roof elevation changes and penetrations should be minimized or eliminated in snow areas. Roof penetrations should be located as close to the ridge or peak of the roof as possible to minimize accumulations of ice and snow.

Building Code Compliance:

Reversed Box Rib is compliant with the IBC, IRC, CBC, and CRC building codes. Refer to IAPMO-UES Code Compliance Report #ER-0550 for further details. Reversed Box Rib is also approved as part of a Class A Fire rated assembly when installed in accordance to UL790 listings.

Panel Attachment / Structural Performance:

The structural performance of Reversed Box Rib is documented in IAPMO-UES Code Compliance Report #ER-0550. Published performance data includes: Panel section properties, inward (gravity) load capacities, outward (wind uplift) load capacities, shear tables, and other product information and limitations.

Oil Canning:

Flat metal surfaces often display waviness commonly referred to as 'oil canning'. This can be caused by variations in raw material, processing variations, product handling, or variations in the installation substrate. Oil canning is a characteristic, not a defect, of panels manufactured from light-gauge metal. To reduce potential for oil canning, substrates should not deviate from a flat plane more than 1/4 inch in 20 feet, or 1/8 inch in 5 feet. Oil canning is not a cause for panel rejection. Additional technical information is available for review on our website.

Protecting the Panels:

Proper handling, storage, installation, and keeping work surfaces clean are key to protecting metal roofing and siding. Regular washing and maintenance after installation further help ensure panel longevity. For detailed guidance, refer to the technical resources on AEP Span's website.

References:

The Sheet Metal and Air Conditioning Contractors' National Association Inc. (SMACNA) manual is an excellent reference for sheet metal contractors. It's guidelines for underlayments, gutter and downspout size requirements, and expansion/contraction of metals and flashing joints should be followed.

Technical Assistance:

Contact your AEP Span Sales Representative for additional information.

Online Product Page:



Technical Resources:



ER-0550 Code Compliance Report:



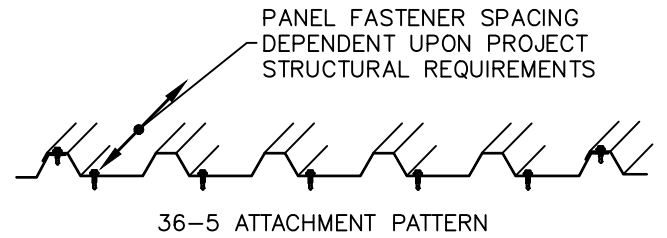
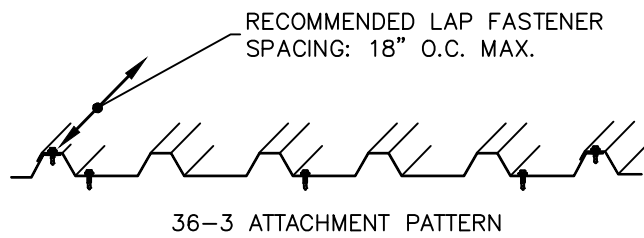
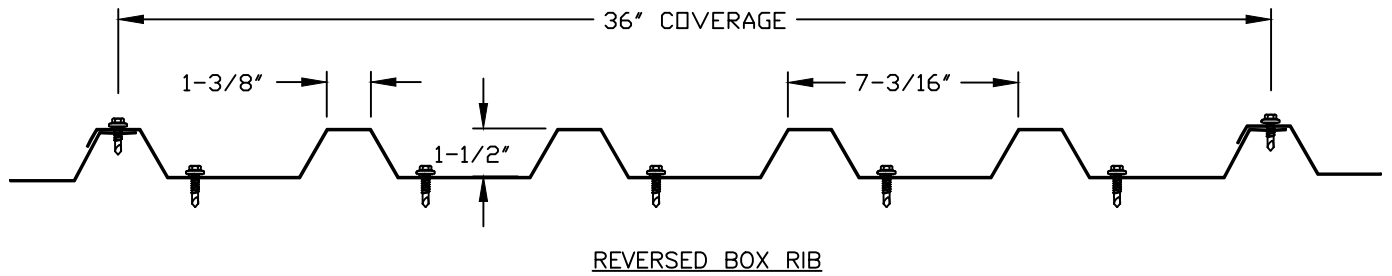

NOTE: PANEL FASTENER ATTACHMENT (TYPE, SIZE, AND LOCATION) IS DEPENDENT UPON SUBSTRATE USAGE AND STRUCTURAL REQUIREMENTS FOR EACH SPECIFIC PROJECT. DESIGN PROFESSIONAL TO DESIGN OR CONFIRM ADEQUATE PANEL ATTACHMENT. REFER TO GENERAL NOTES SECTION FOR ADDITIONAL GUIDANCE.

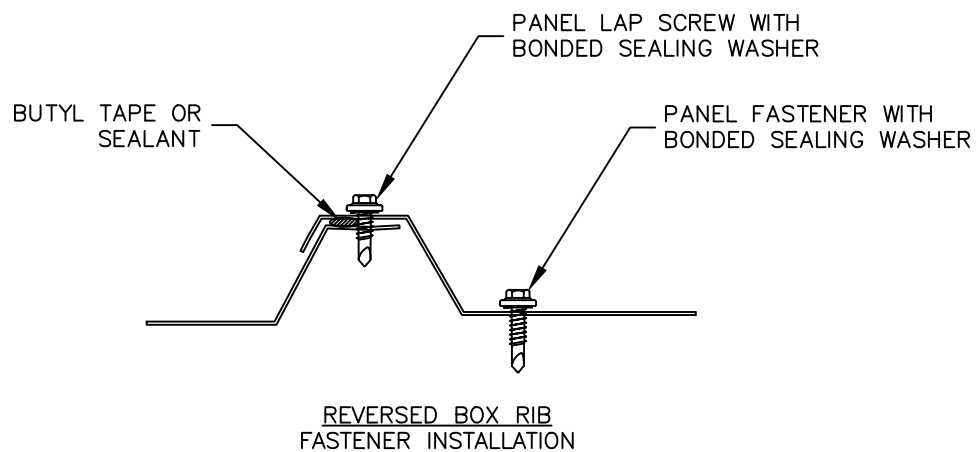





REVERSED BOX RIB



PANEL DETAILS

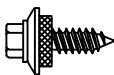
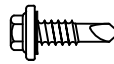

RBR-01

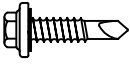
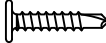
Description	Length(s)	Use
 #9 Hex Head Wood Screw (1/4" Drive) with Sealing Washer	1", 1-1/2" 2", 2-1/2" 3"	Panel to dimensional lumber attachments. Color matched.
 #14 Hex Head Wood Screw (5/16" Drive) with Sealing Washer	1" 1-1/2"	Panel to plywood/OSB attachments (7/16" minimum thickness). Color matched.
 #12 Stitch Screw (1/4" Hex Drive) with Sealing Washer	3/4"	Exposed trim and panel lap attachments. Visible head size matches Item #1 wood screw. Color matched.
 #14 Lap Self Driller (5/16" Hex Drive) with Sealing Washer	7/8"	Exposed trim and panel lap attachments. Visible head size matches Item #2 wood screw. Color matched.
 1/8" Diameter Stainless Steel Rivet	1/8" Max Grip Length	Trim to trim, or trim to panel attachments. Color matched.
 #12 Hex Head Self Drill Screw (1/4" Drive)	1", 1-1/2" 2", 2-1/2"	Panel to steel deck or steel framing attachment. Color matched.
 #10 Pan Head Screw	1"	For non-exposed trim to substrate attachments.

Notes:

- The table above shows the fasteners commonly required for AEP Span panel installations. Refer to the enclosed installation details for further guidance.
- Panel attachment screws into plywood/OSB must be long enough to fully penetrate through at least 3/8", or penetrate into solid lumber by at least one inch.
- Exposed fasteners must have sealing washers and should be the same color as the panels and trims they attach.
- Screws must be properly driven to ensure proper seal and holding strength. Do not underdrive or overdrive the screws.
- Note that rivets are not considered watertight.

Proper Installation of Fasteners with Sealing Washers

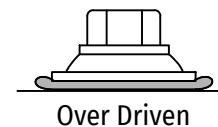
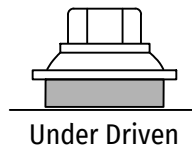
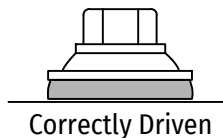

**REVERSED
BOX RIB**



FASTENERS

RBR-02

ROOF DETAILS



REVERSED
BOX RIB



RBR-03

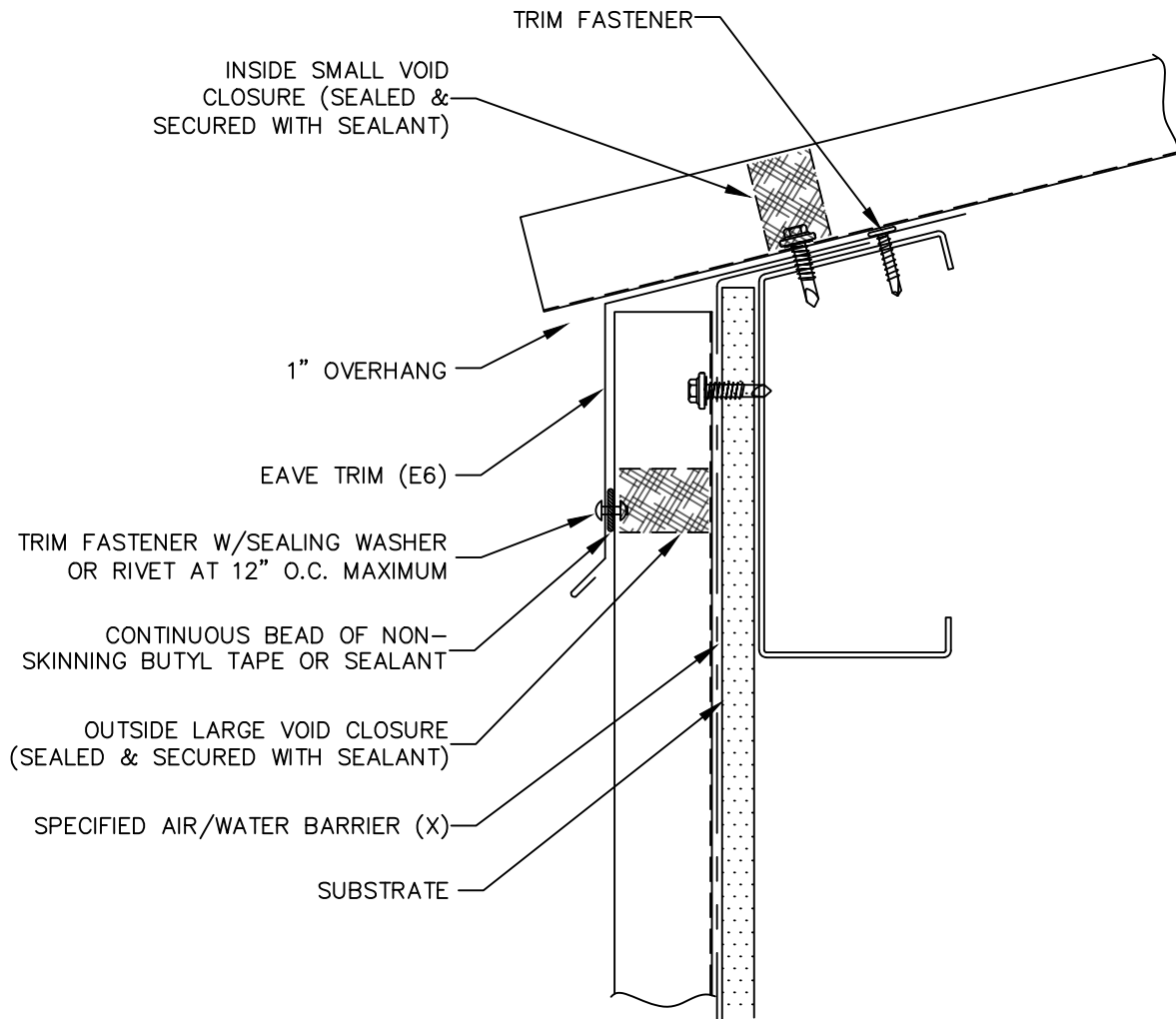
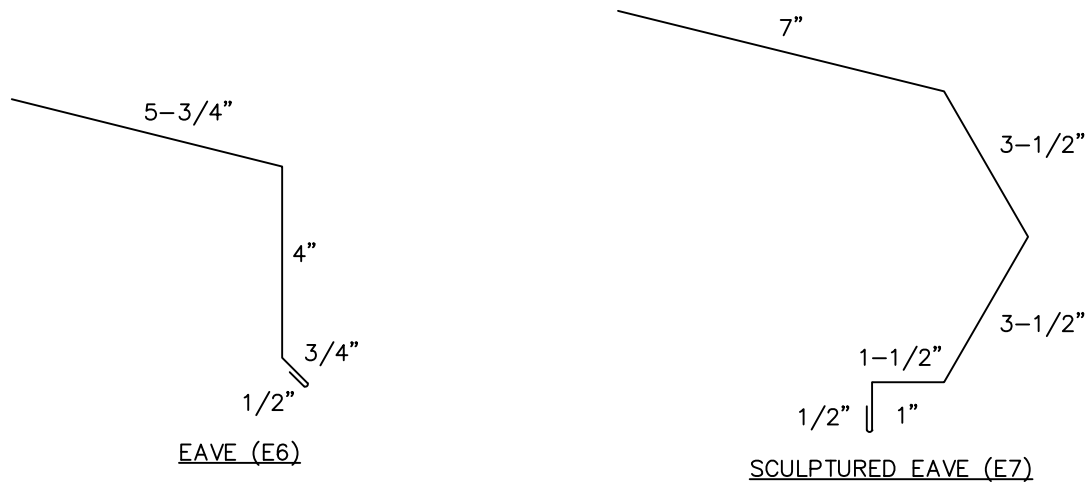

(X) - NOT BY AEP SPAN



REVERSED
BOX RIB



EAVE

RBR-04

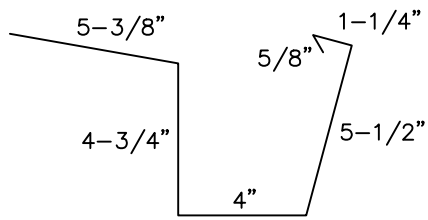

GUTTER, PRE-HUNG (GU6)

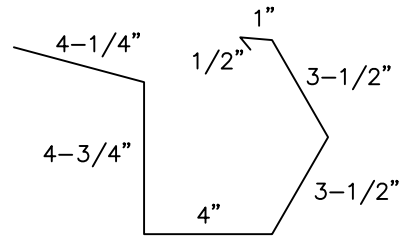

SCULPTURED GUTTER, PRE-HUNG (GU7)

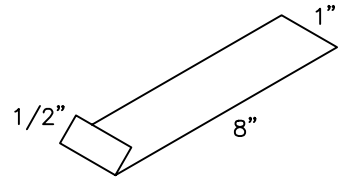

GUTTER STRAP (GS6)

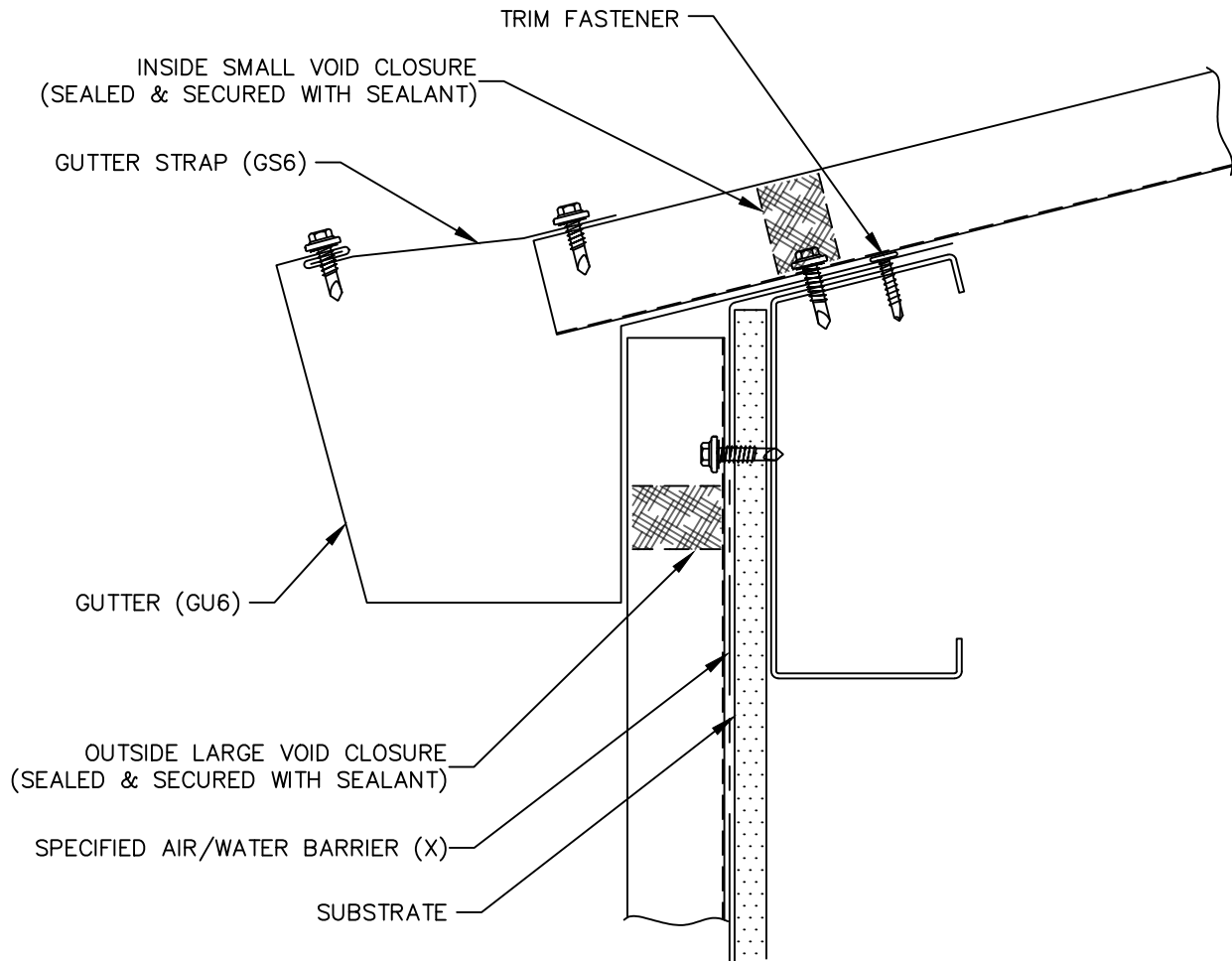

(X) - NOT BY AEP SPAN



REVERSED
BOX RIB



EAVE W/ GUTTER
(PRE-HUNG)

RBR-05

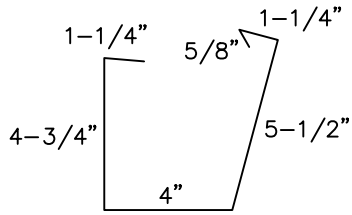

GUTTER, POST-HUNG (GU8)

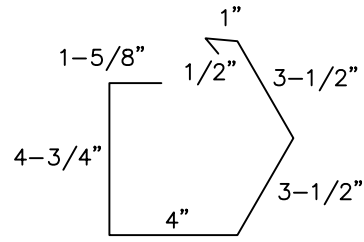

SCULPTURED GUTTER, POST-HUNG (GU9)

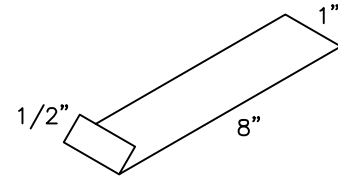

GUTTER STRAP (GS6)

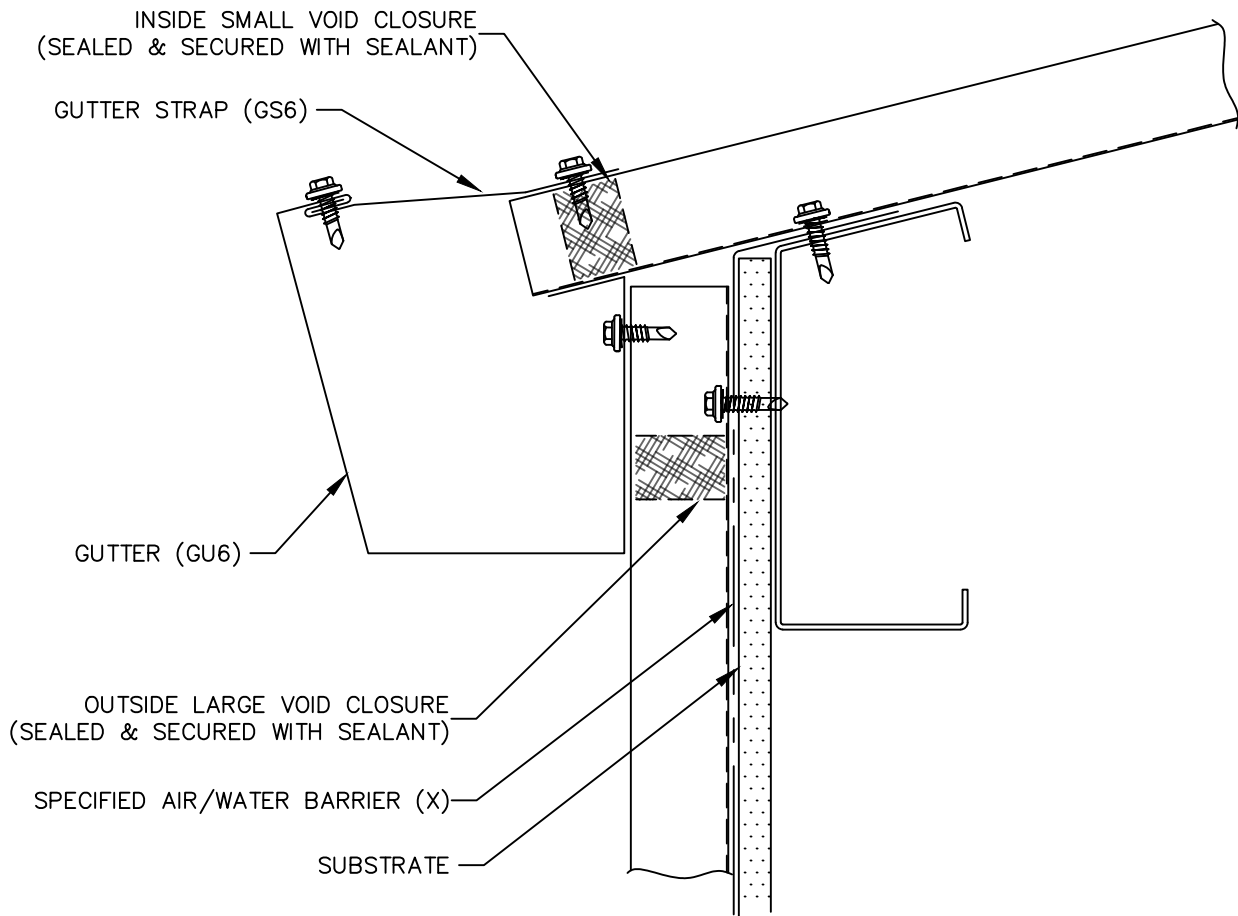

(X) - NOT BY AEP SPAN



REVERSED
BOX RIB



EAVE W/ GUTTER
(POST-HUNG)



RBR-06

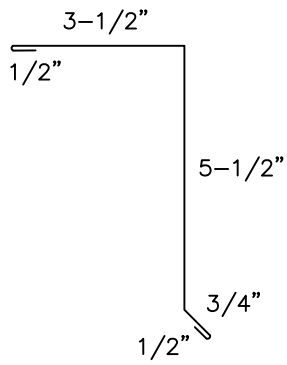

GABLE TRIM (G12)

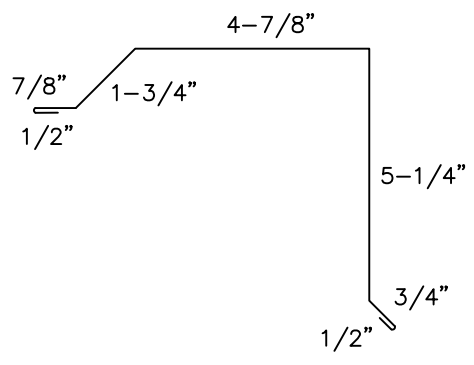

ALTERNATE GABLE (G8)

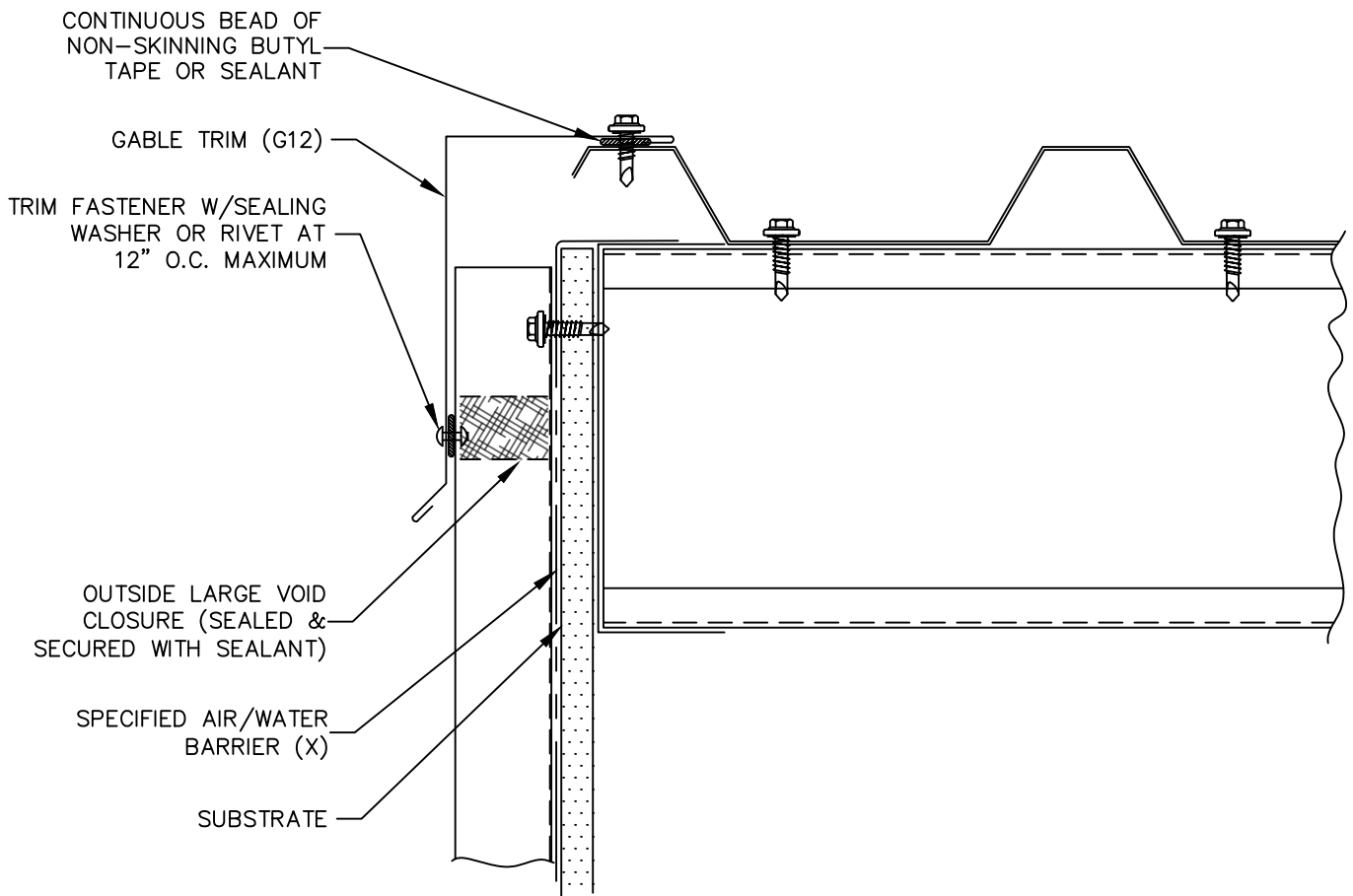

(X) - NOT BY AEP SPAN



REVERSED
BOX RIB



GABLE



RBR-07

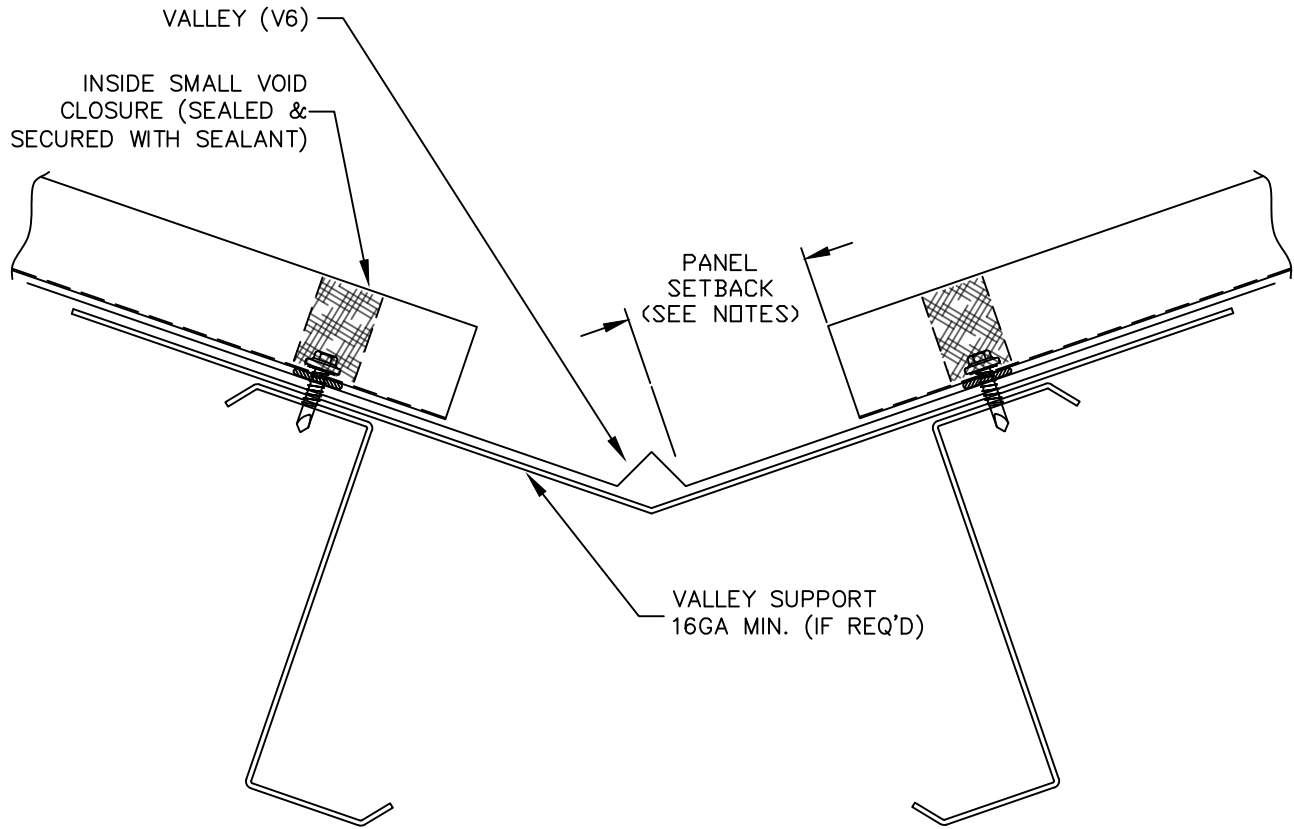
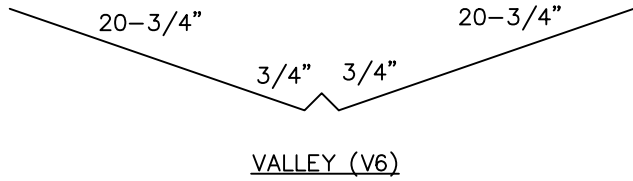

NOTES:

- PANEL SETBACK 8" MIN FROM VALLEY CENTERLINE. PROJECT CONDITIONS (SLOPE, ICE, EXCESSIVE SNOW OR RAIN) MAY REQUIRE LARGER SETBACK. CONSULT DESIGN PROFESSIONAL AS NEEDED FOR ASSISTANCE.
- VALLEY MUST BE THE PROPER WIDTH TO ACCOUNT FOR SLOPE, SNOW, ICE AND HEAVY RAIN CONDITIONS.

- A RUBBERIZED COLD-APPLIED MEMBRANE IS RECOMMENDED, EXTENDING A MINIMUM OF 3'-0" UP FROM THE CENTER OF THE VALLEY ON EACH SIDE.
- BE ADVISED THAT ROOF VALLEYS INSTALLED IN REGIONS OF WILDFIRE RISK MAY REQUIRE AN ALTERNATE CONSTRUCTION TO MEET CODE REQUIREMENTS.



**REVERSED
BOX RIB**



VALLEY

RBR-08

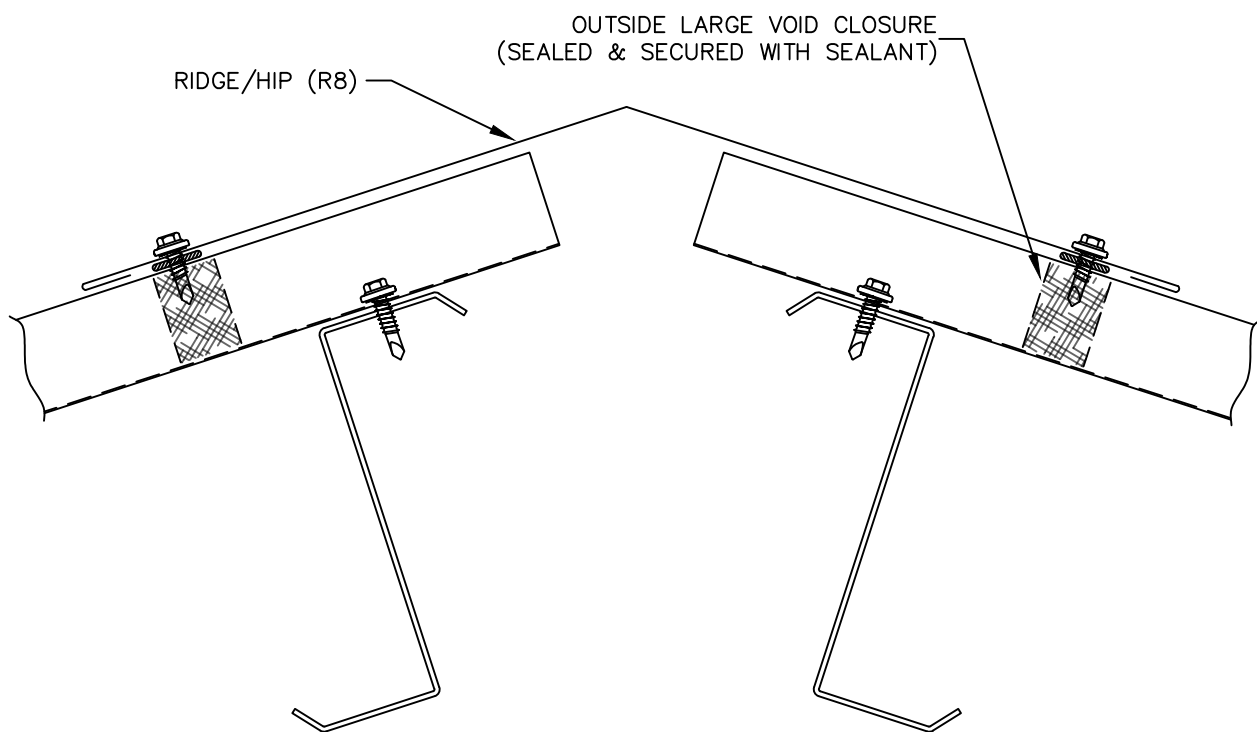
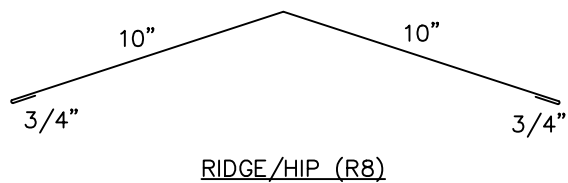

REVERSED
BOX RIB



RIDGE



RBR-09

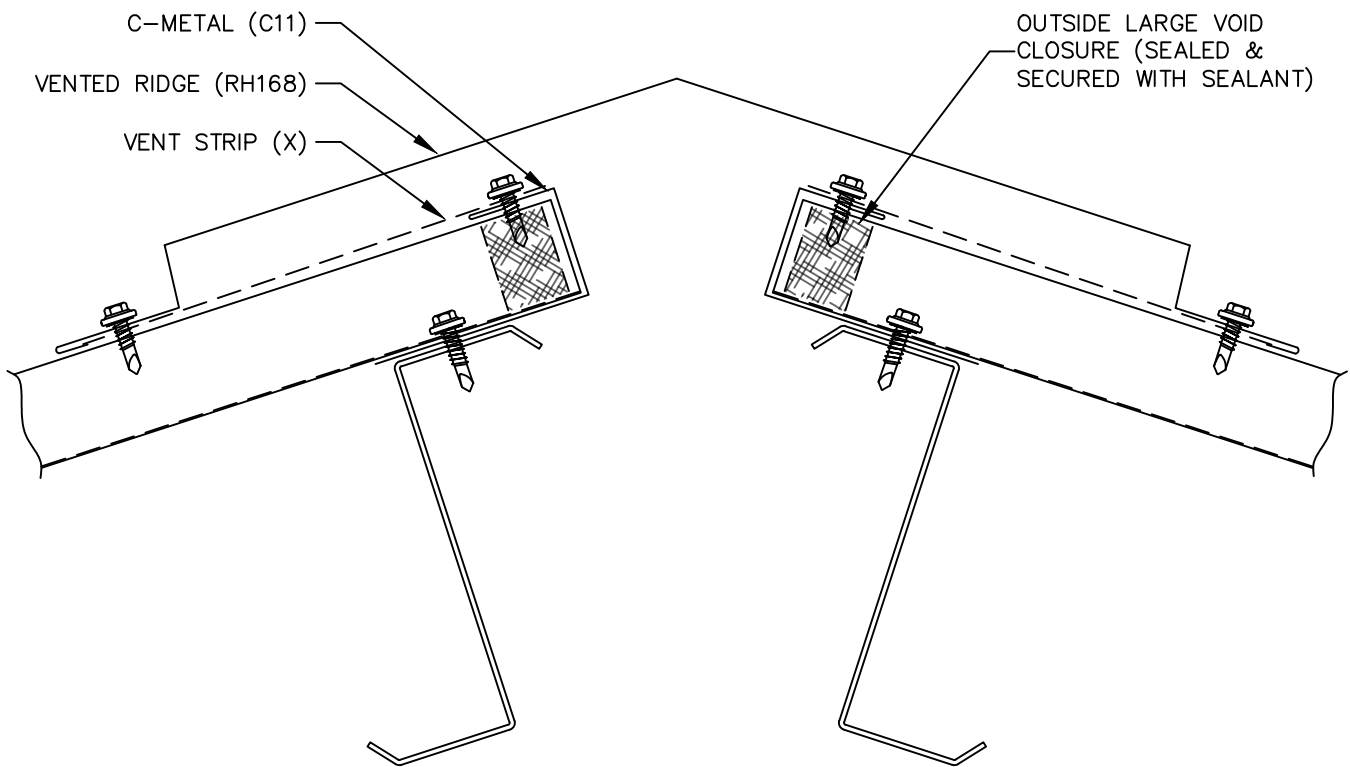
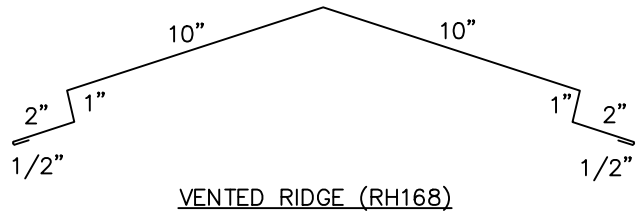
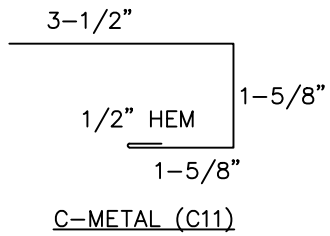

NOTE:
- THIS DETAIL MEETS IWUC AND CALIFORNIA CBC CHAPTER 7A FIRE CODE REQUIREMENTS IF: VENT MATERIAL IS NON-COMBUSTIBLE METAL, HAS A CORROSION RESISTANT FINISH (GALVANIZED, OR SIMILAR), AND HAS VENT HOLES BETWEEN 1/16" AND 1/8" IN DIAMETER.

(X) - NOT BY AEP SPAN



REVERSED
BOX RIB



VENTED RIDGE



RBR-10

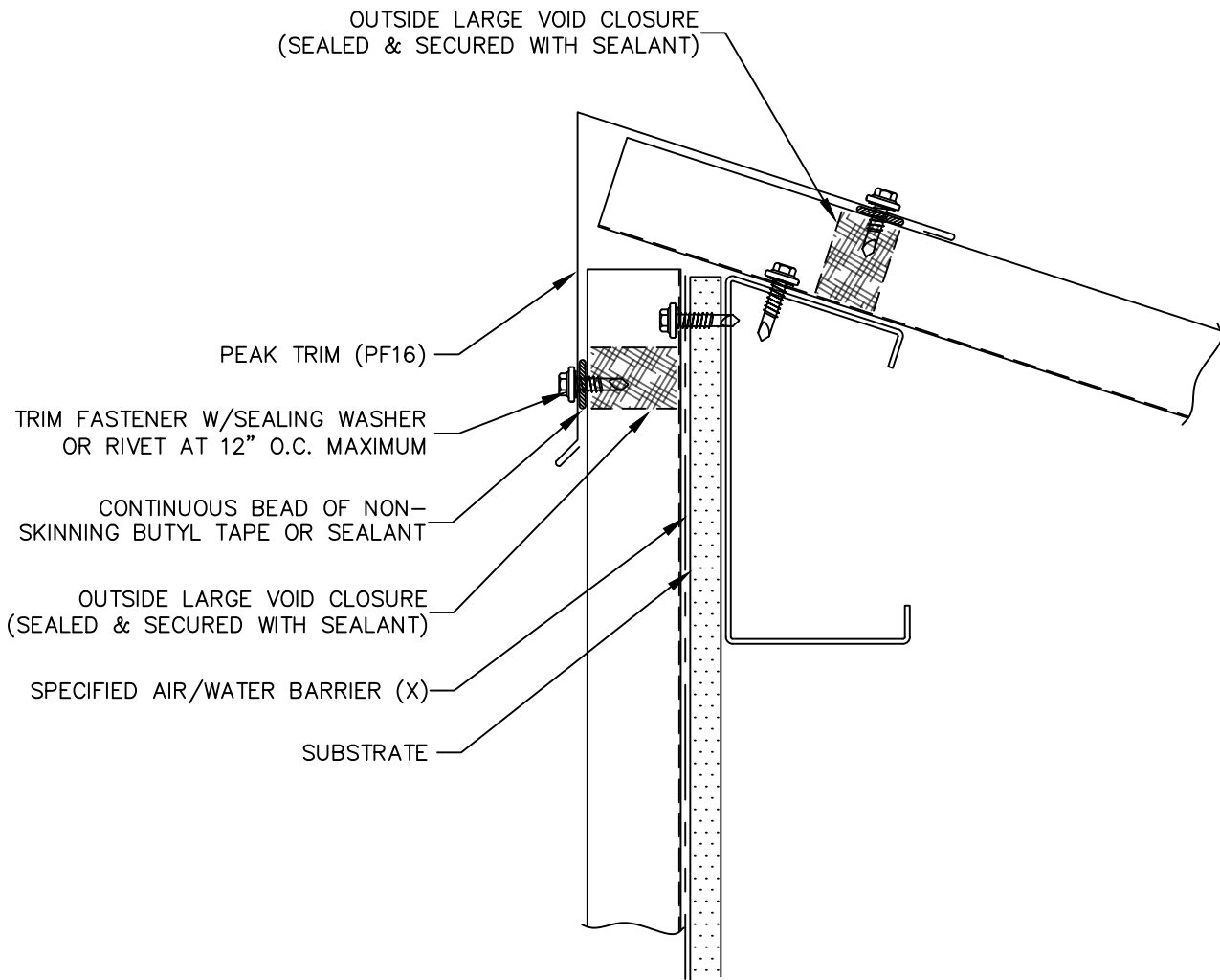
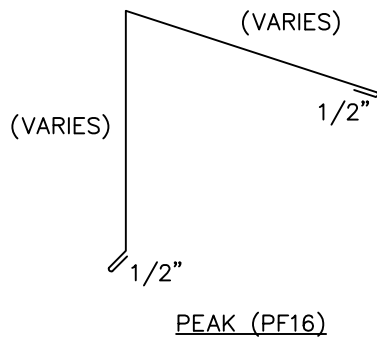

(X) - NOT BY AEP SPAN



REVERSED
BOX RIB



PEAK

RBR-11

5-1/4"

5"

1/2"

SIDEWALL (SW8)

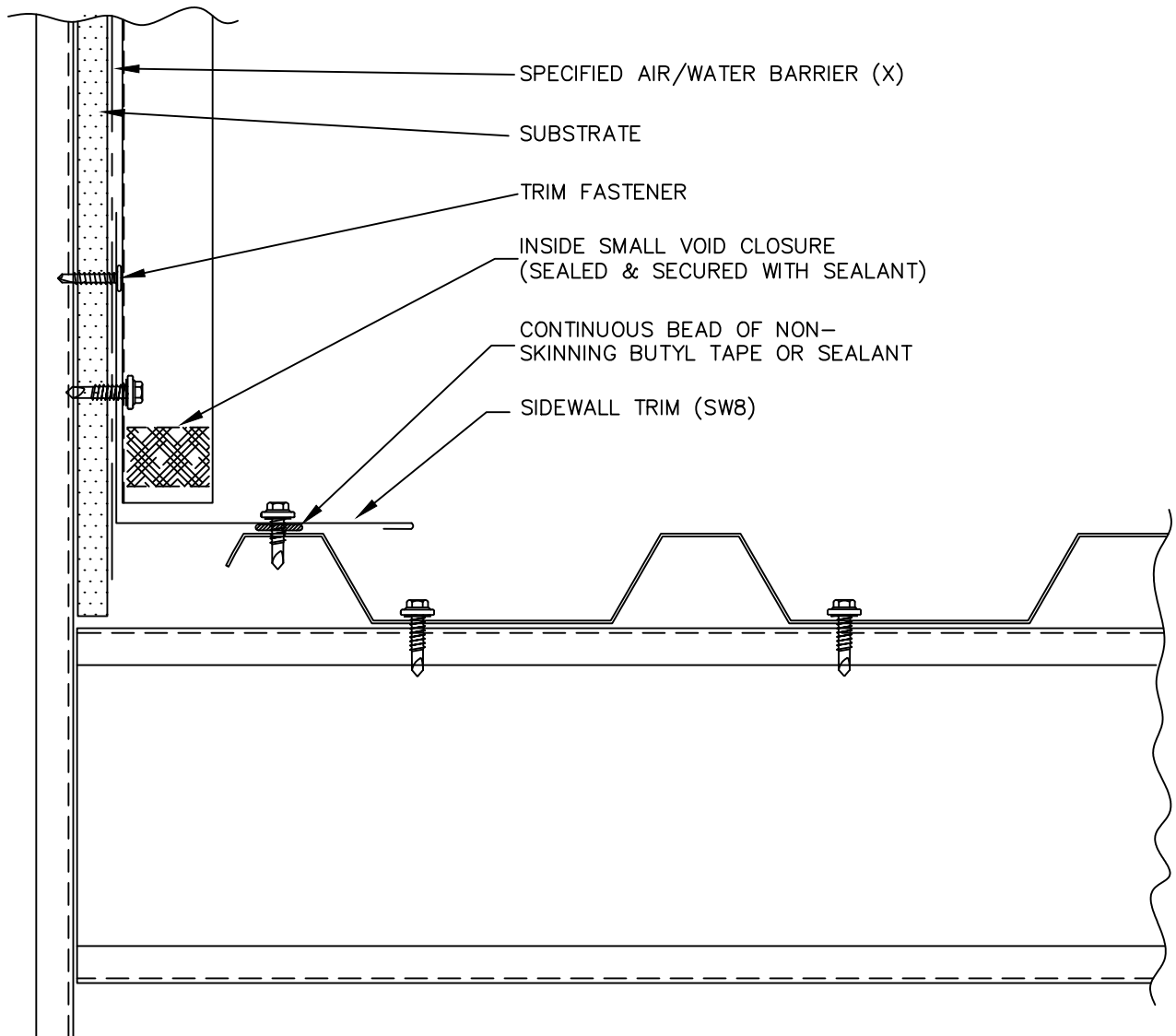

(X) - NOT BY AEP SPAN



REVERSED
BOX RIB



SIDEWALL



RBR-12

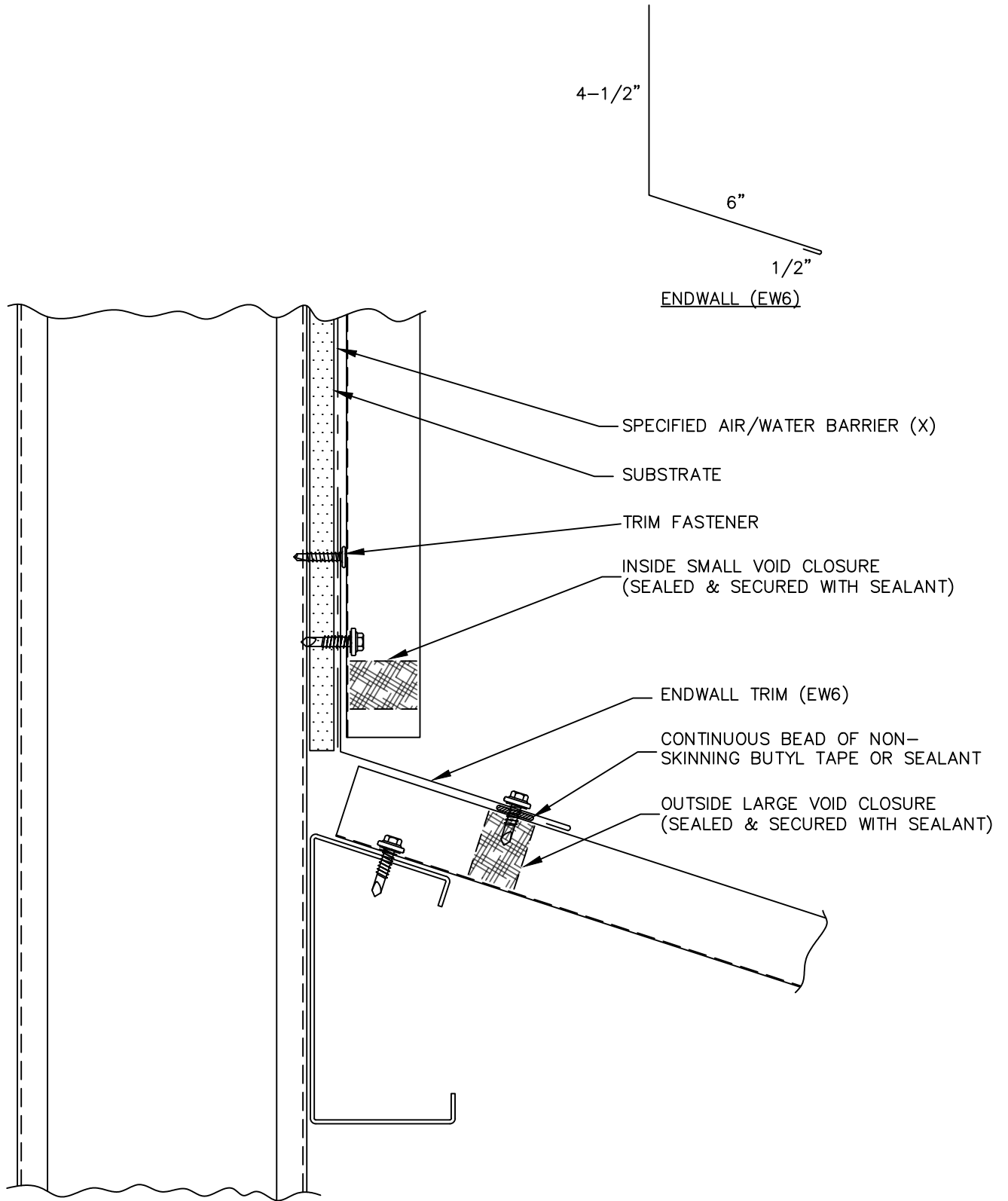

(X) - NOT BY AEP SPAN



REVERSED
BOX RIB



ENDWALL



RBR-13

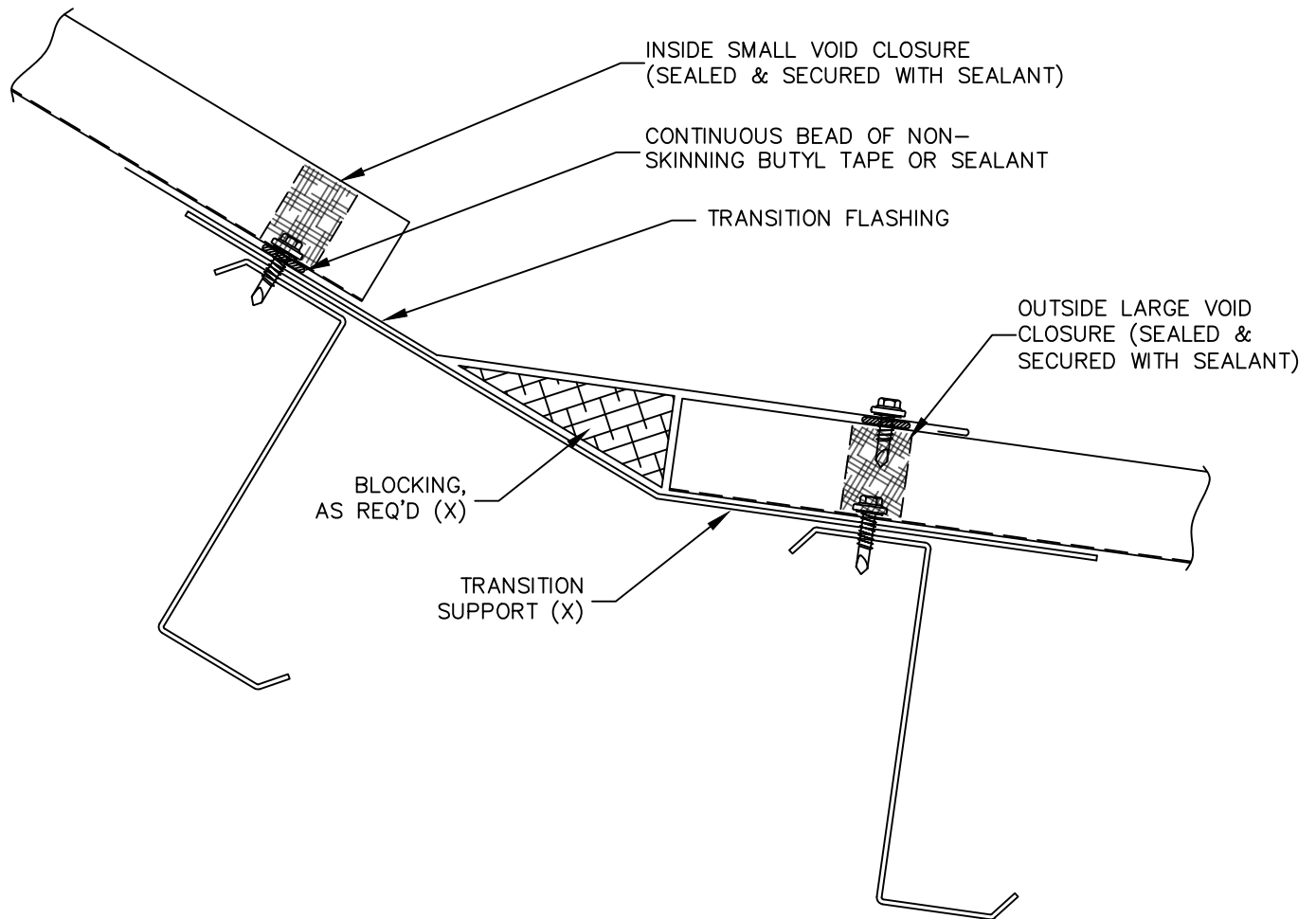

(X) - NOT BY AEP SPAN



REVERSED
BOX RIB



HI-LO TRANSITION



RBR-14

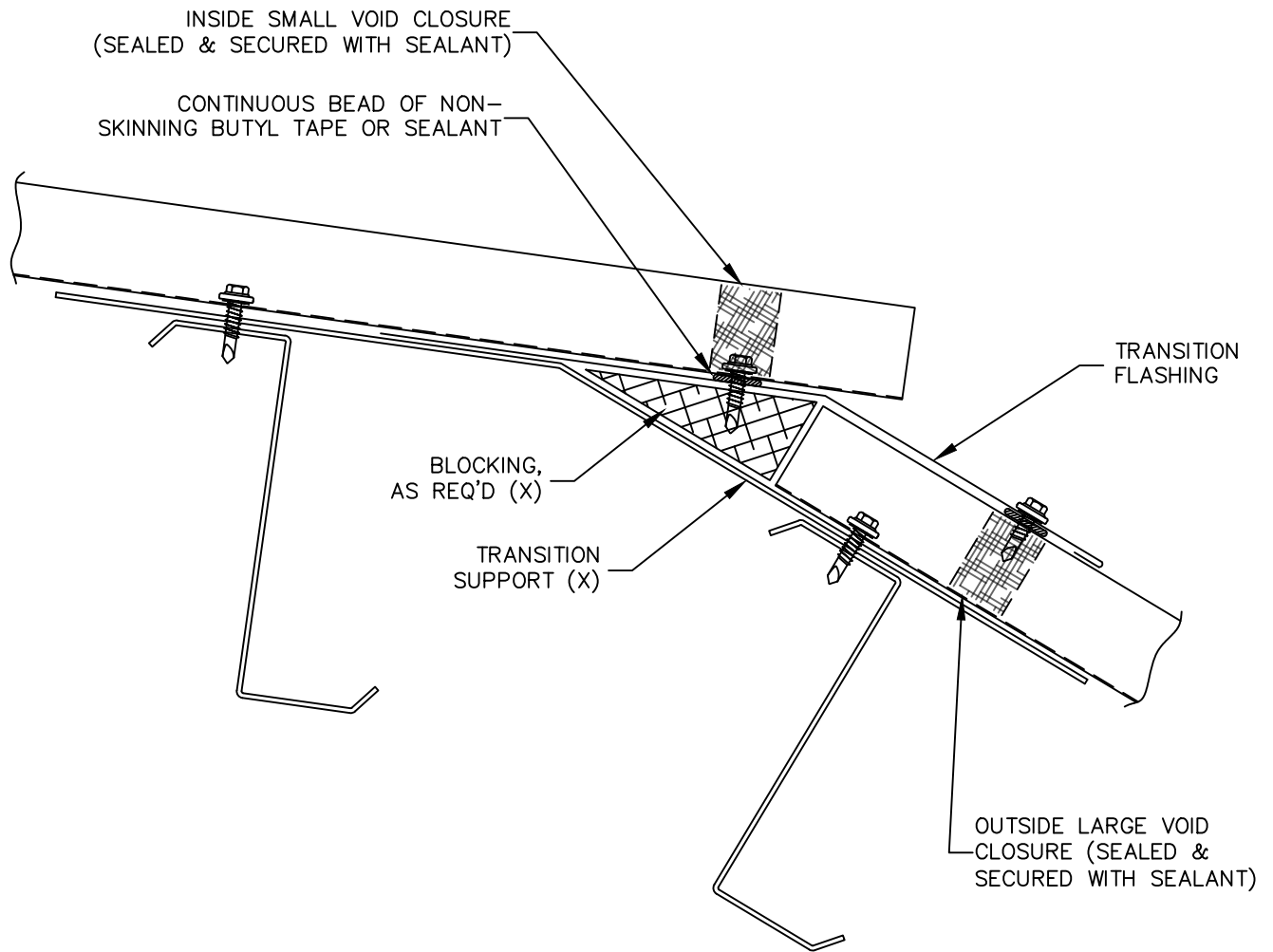

(X) - NOT BY AEP SPAN



REVERSED BOX RIB



LO-HI TRANSITION



RBR-15

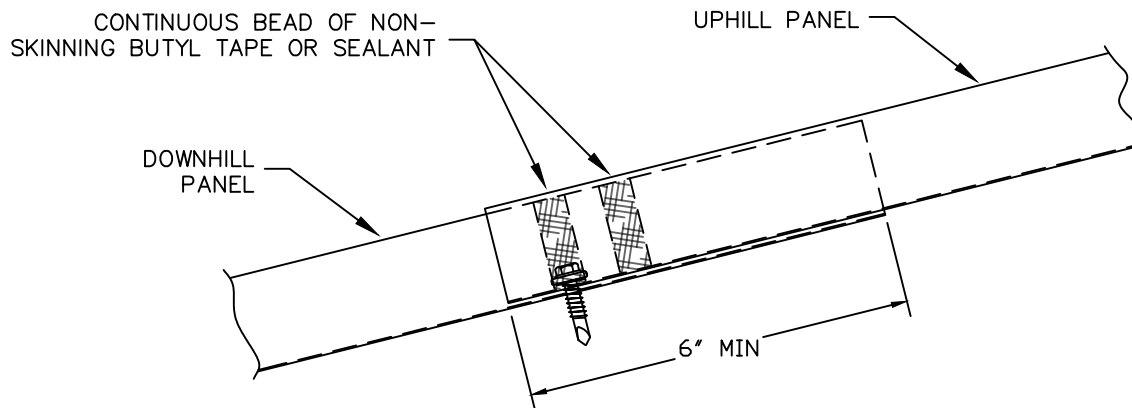

REVERSED
BOX RIB



PANEL LAP



RBR-16

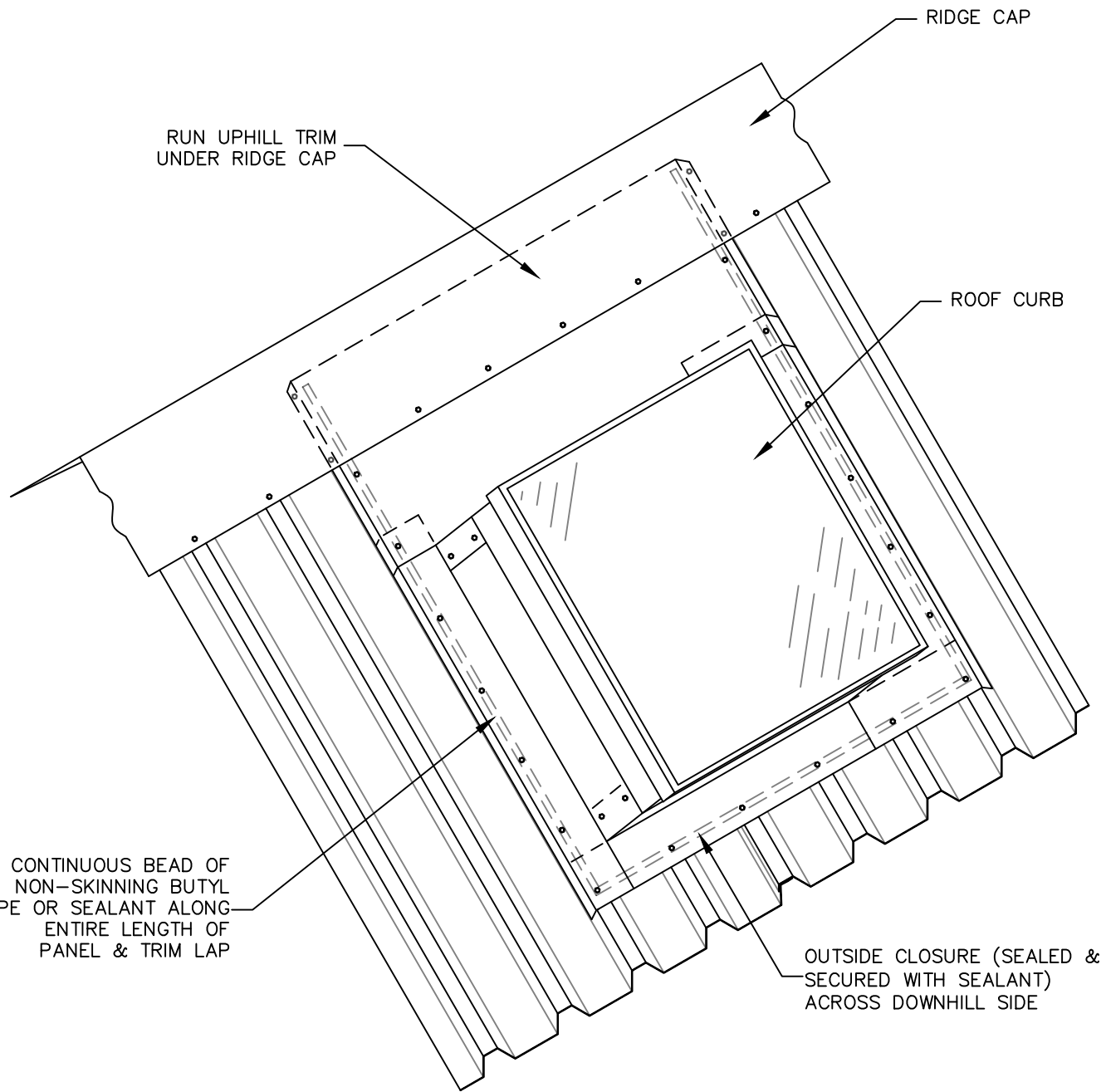

SEE FOLLOWING PAGE FOR EXPLODED VIEW.



REVERSED
BOX RIB



ROOF CURB



RBR-17

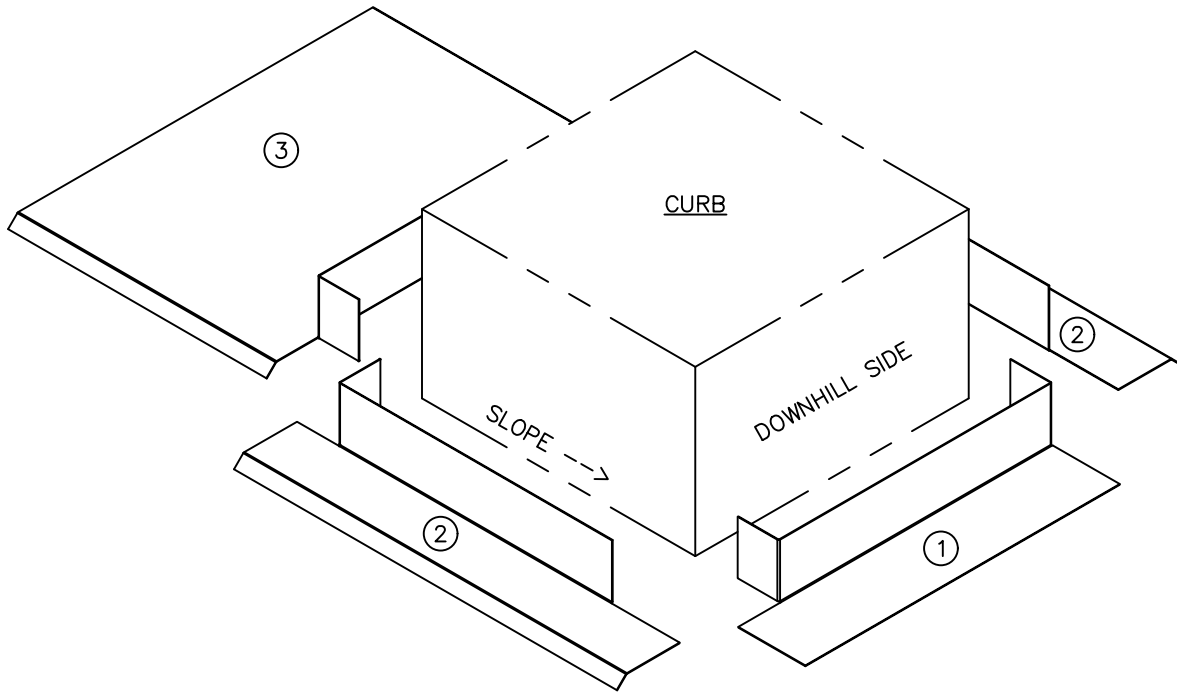

INSTALL CURB TRIMS IN ORDER SHOWN:

- 1) BOTTOM TRIM
- 2) CURB SIDE TRIMS
- 3) TOP TRIM

OVERLAP TRIMS IN SHINGLED MANNER
WITH CONTINUOUS BEADS OF SEALANT
AT ALL LAPS.

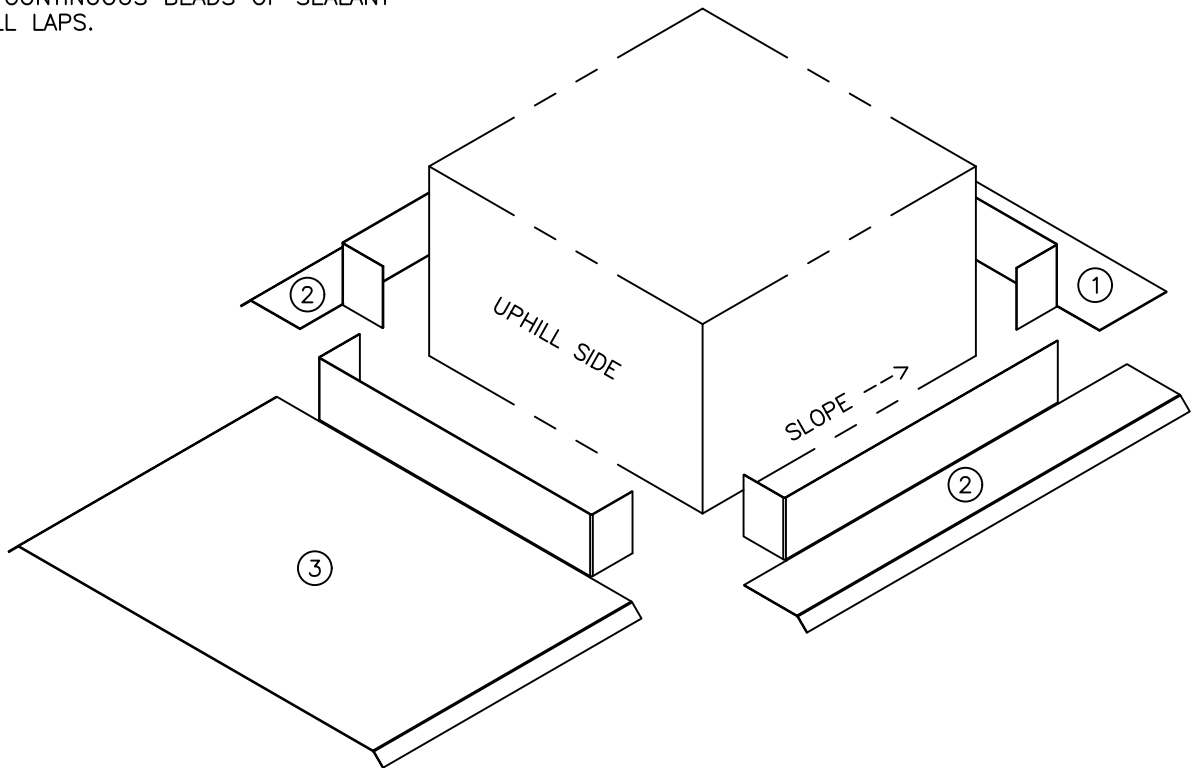

REVERSED
BOX RIB



CURB FLASHINGS

RBR-18

VERTICAL WALL DETAILS



REVERSED
BOX RIB



RBR-19

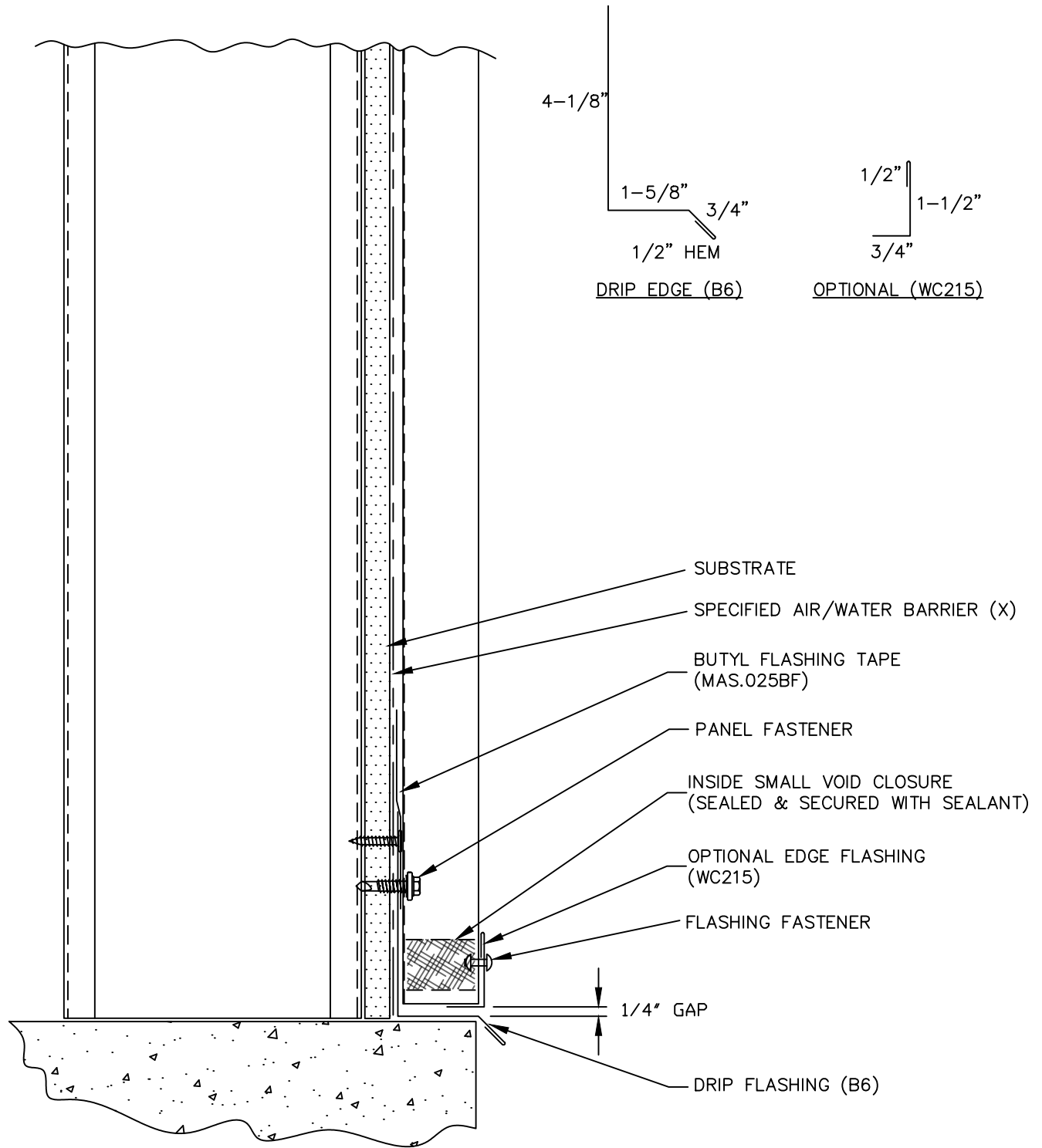

REVERSED
BOX RIB



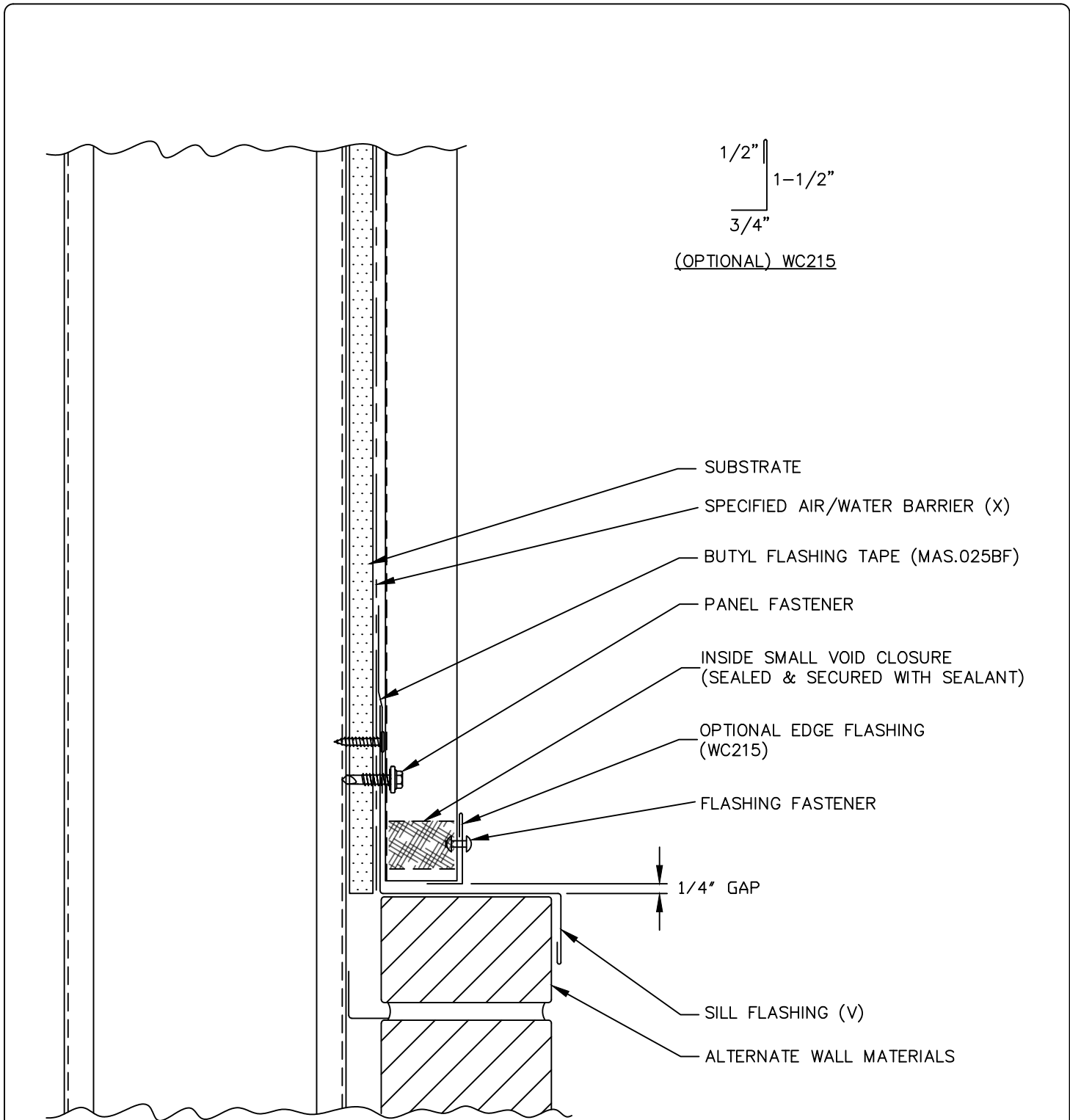

BASE

RBR-20

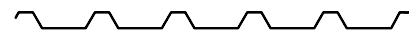

(X) - NOT BY AEP SPAN
 (V) - DIMENSIONS VARY BASED ON PROJECT CONDITIONS

	<p>REVERSED BOX RIB</p> 	SILL
		 RBR-21

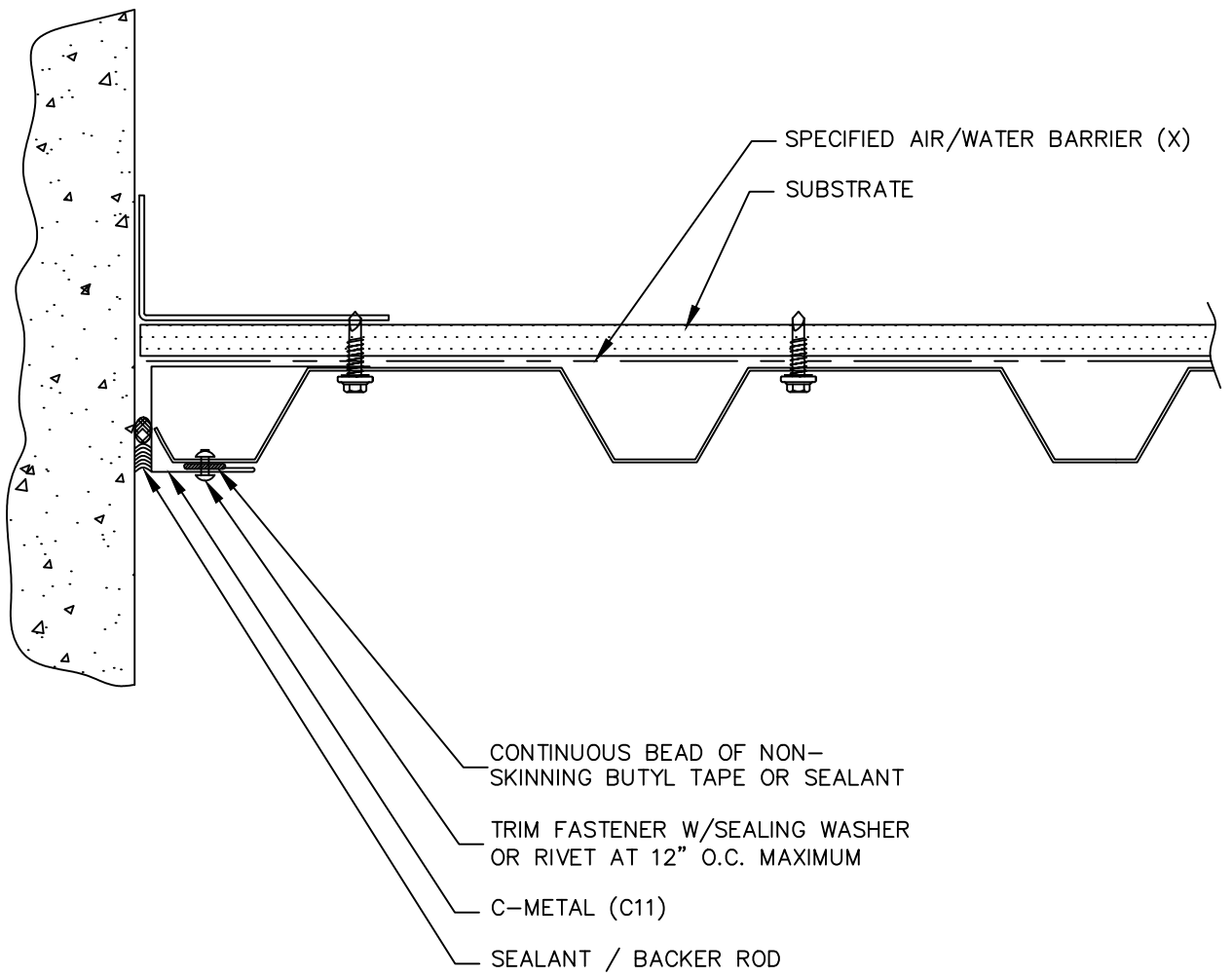
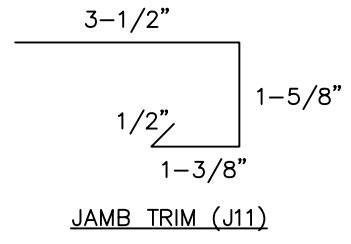
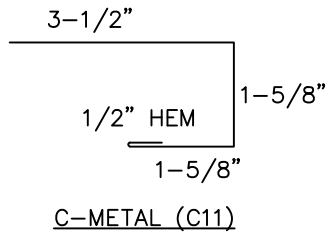

(X) - NOT BY AEP SPAN



REVERSED
BOX RIB

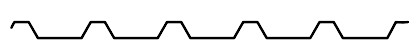

END WALL



RBR-22

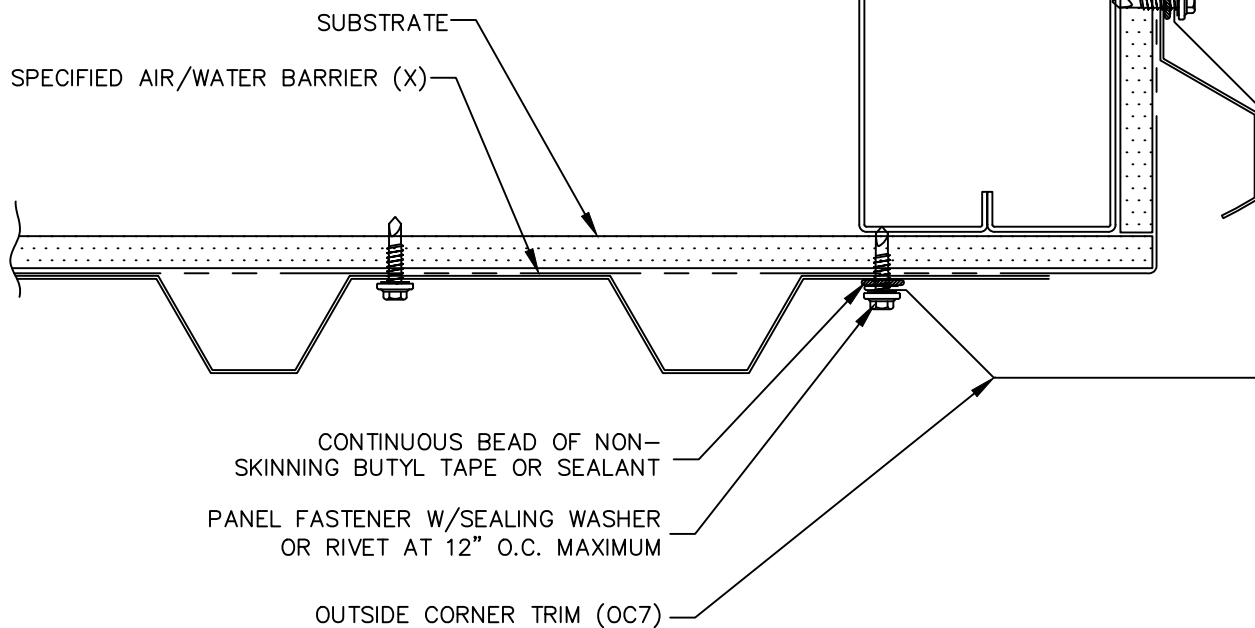
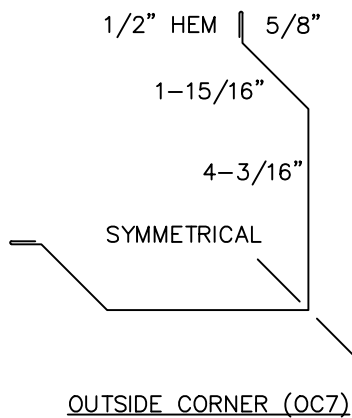
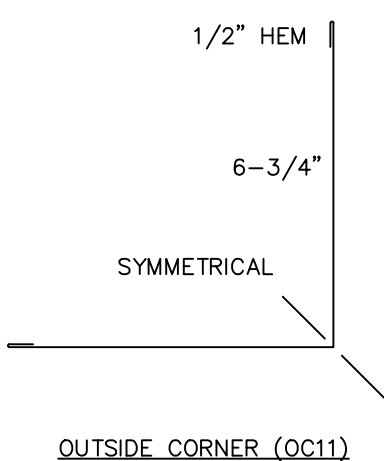

(X) - NOT BY AEP SPAN



REVERSED
BOX RIB



OUTSIDE CORNER



RBR-23

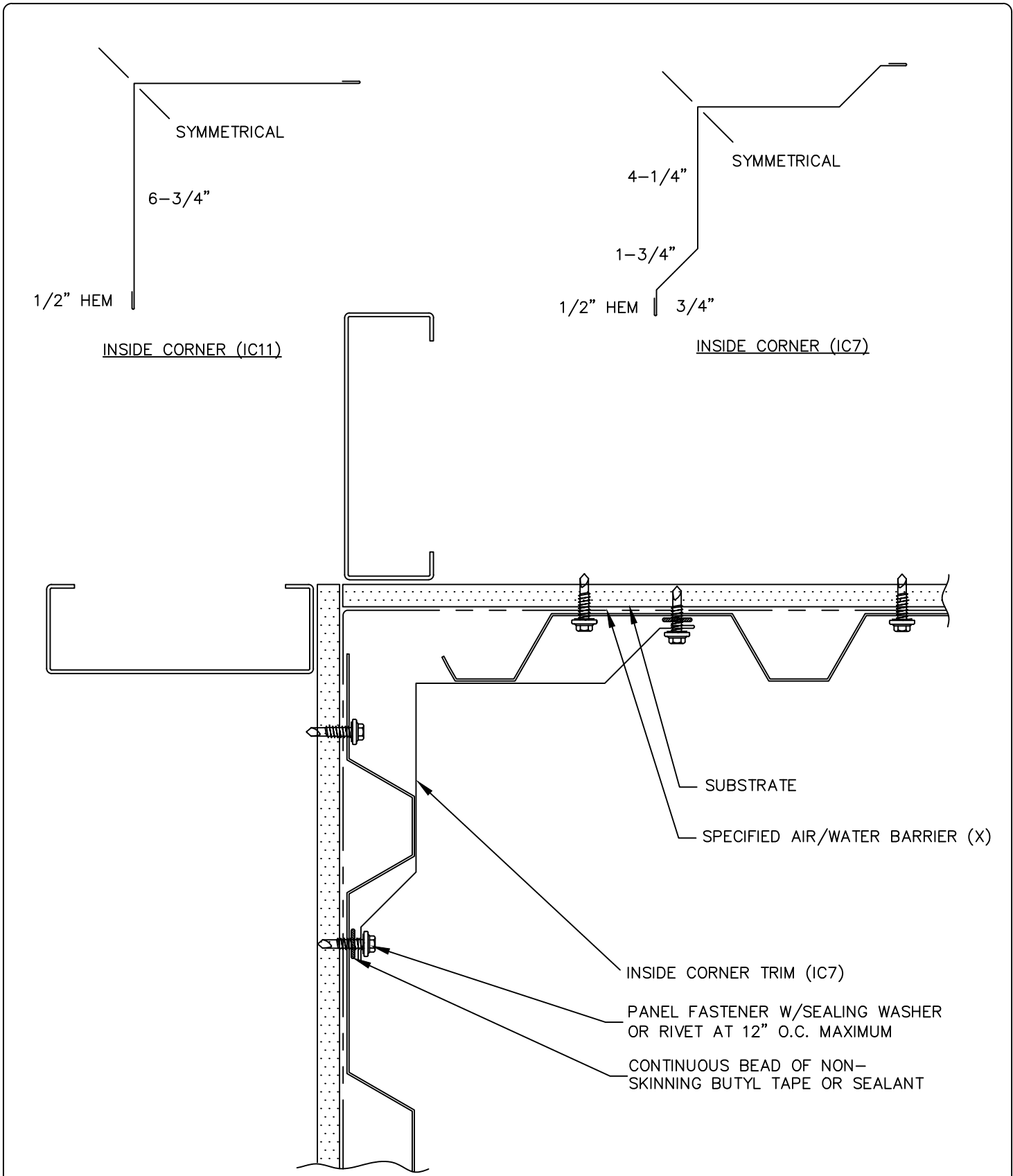

(X) - NOT BY AEP SPAN



REVERSED
BOX RIB

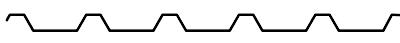

INSIDE CORNER



RBR-24

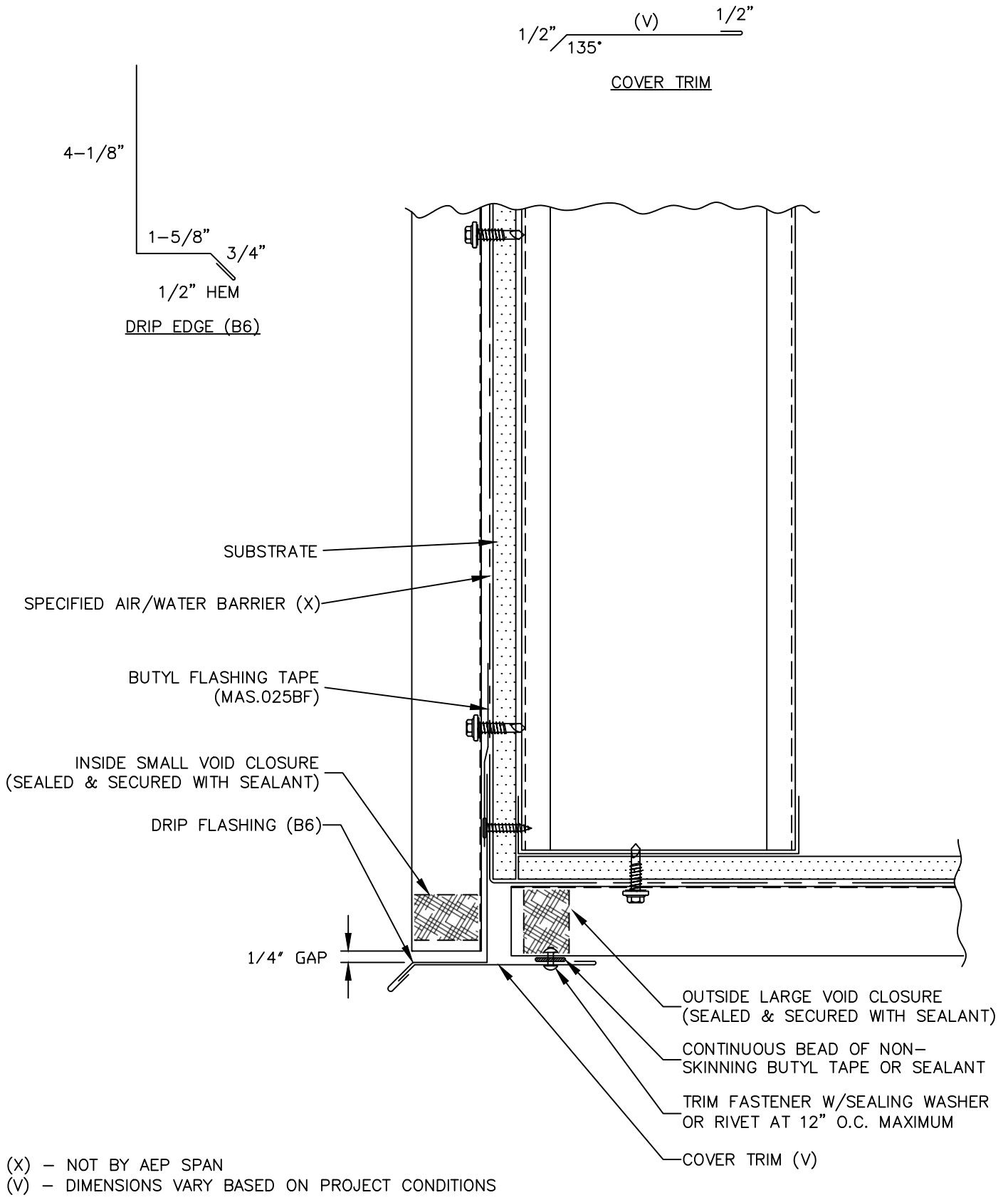

**REVERSED
BOX RIB**



SOFFIT (FRONT)



RBR-25

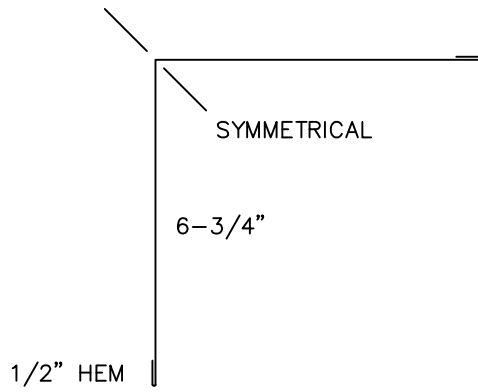

INSIDE CORNER (IC11)

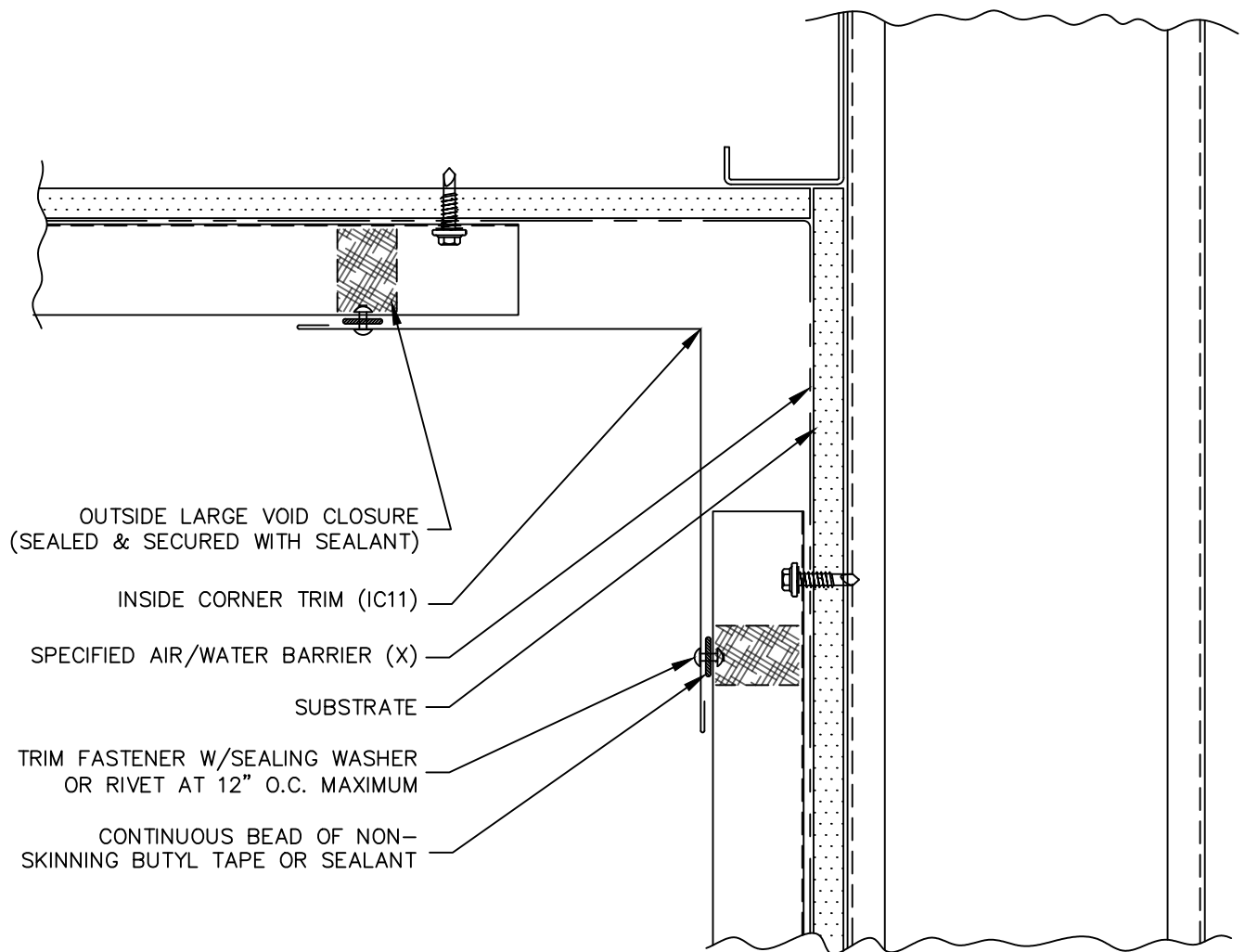

(X) - NOT BY AEP SPAN



REVERSED
BOX RIB



SOFFIT (BACK)



RBR-26

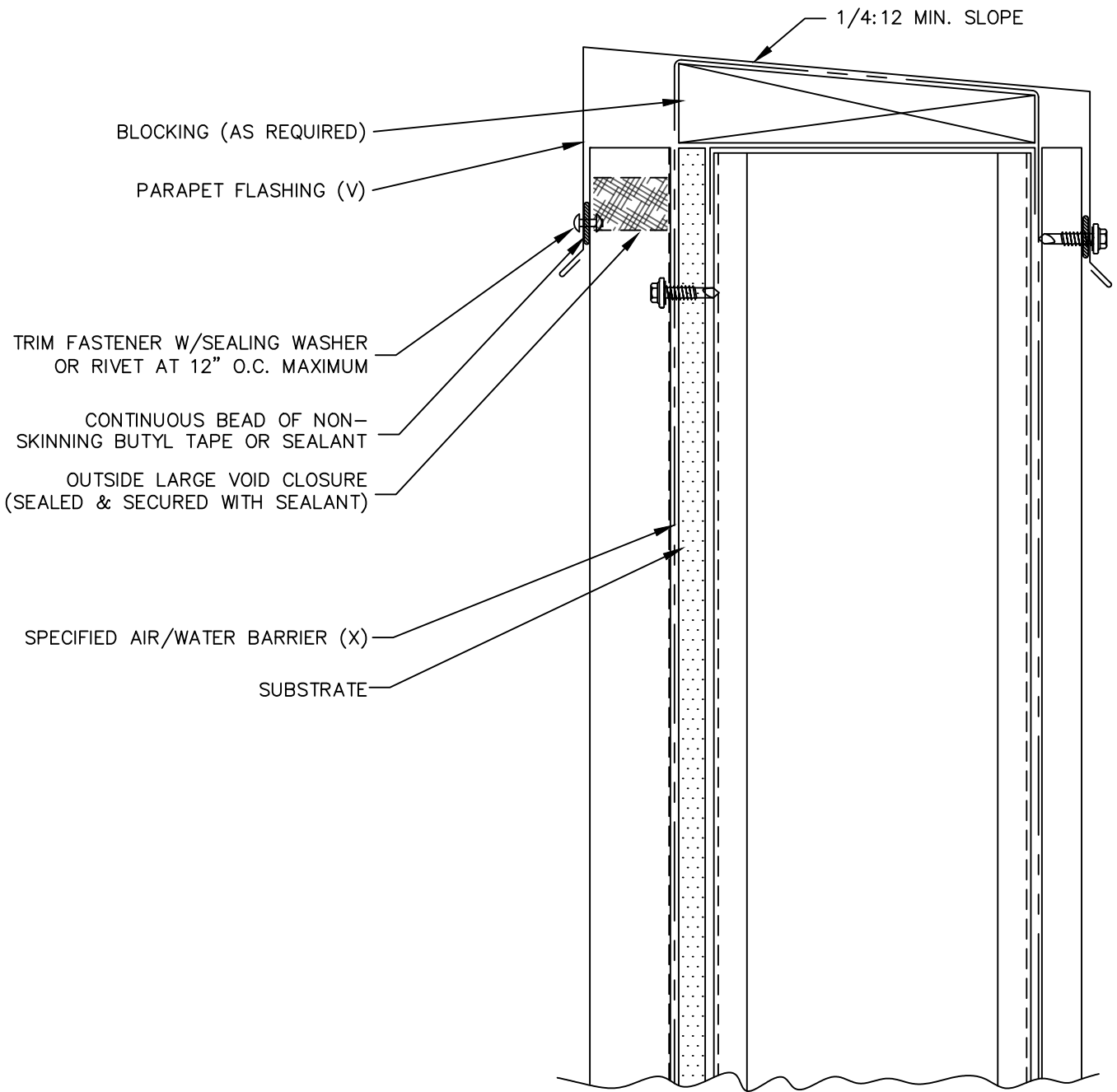

(X) - NOT BY AEP SPAN
 (V) - DIMENSIONS VARY BASED ON PROJECT CONDITIONS



REVERSED
 BOX RIB



PARAPET



RBR-27

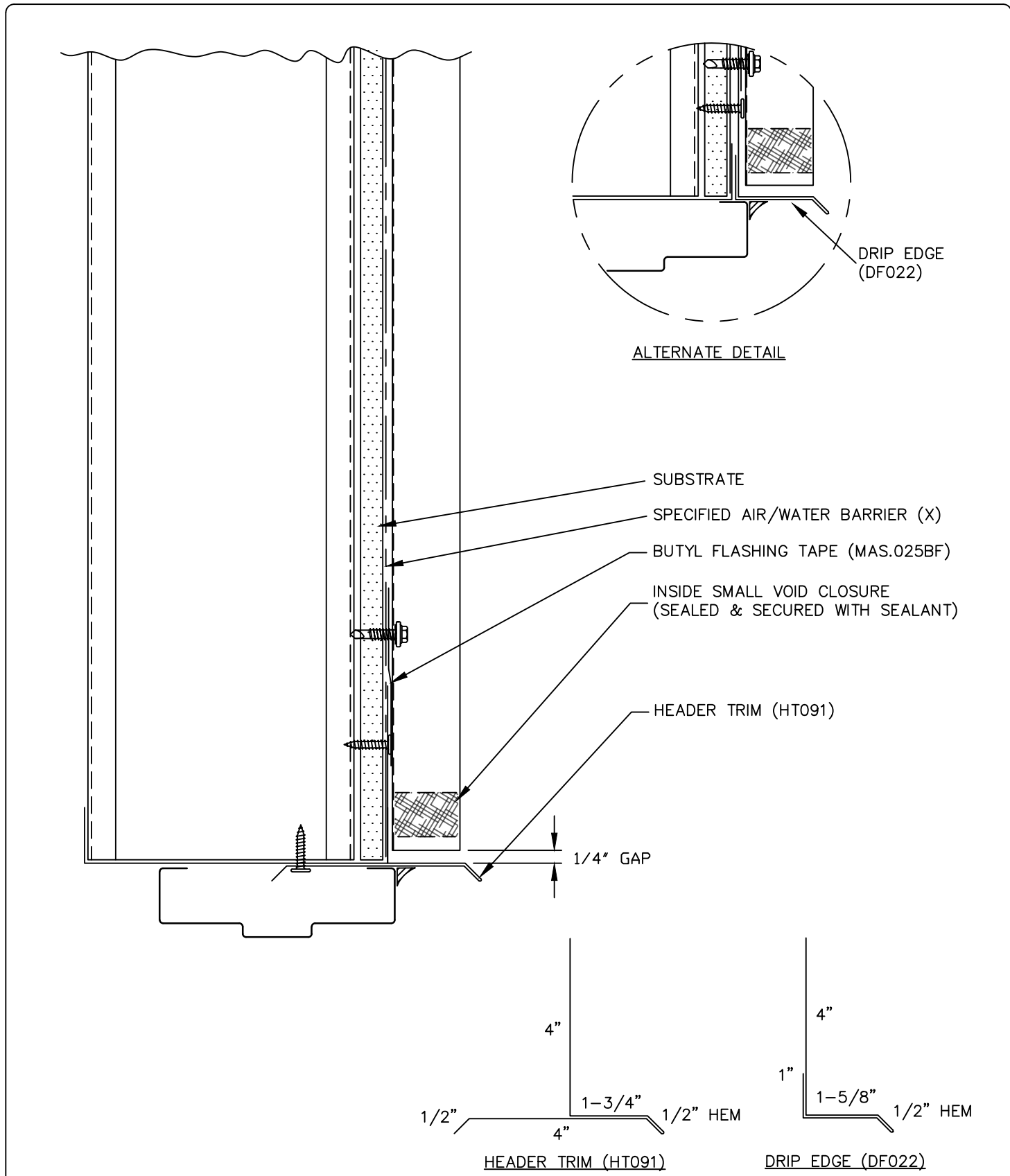

(X) - NOT BY AEP SPAN



REVERSED BOX RIB



DOOR / WINDOW (HEAD)



RBR-28

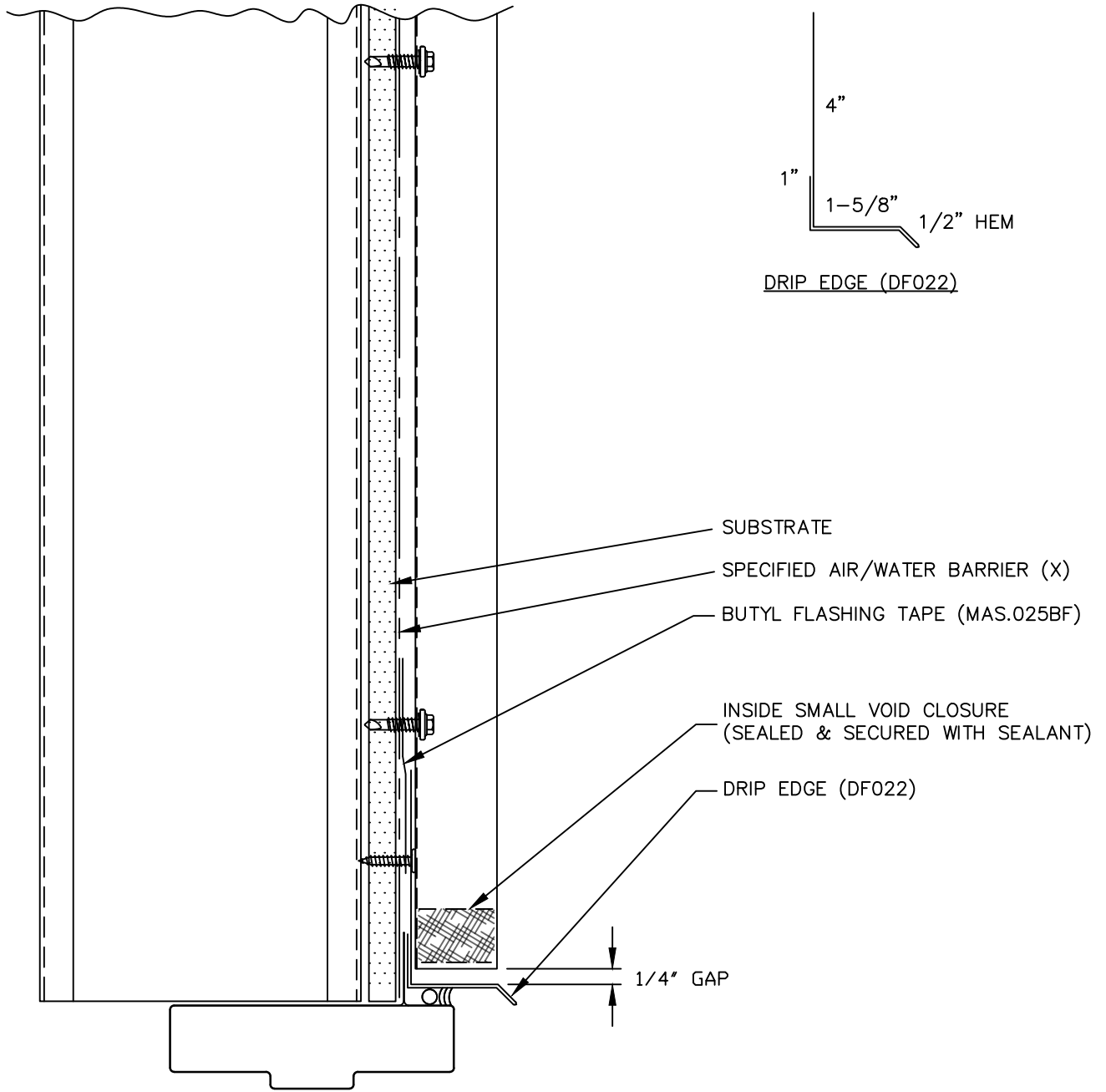

REVERSED
BOX RIB



OPENING, HEAD
(NAIL FIN)



RBR-29

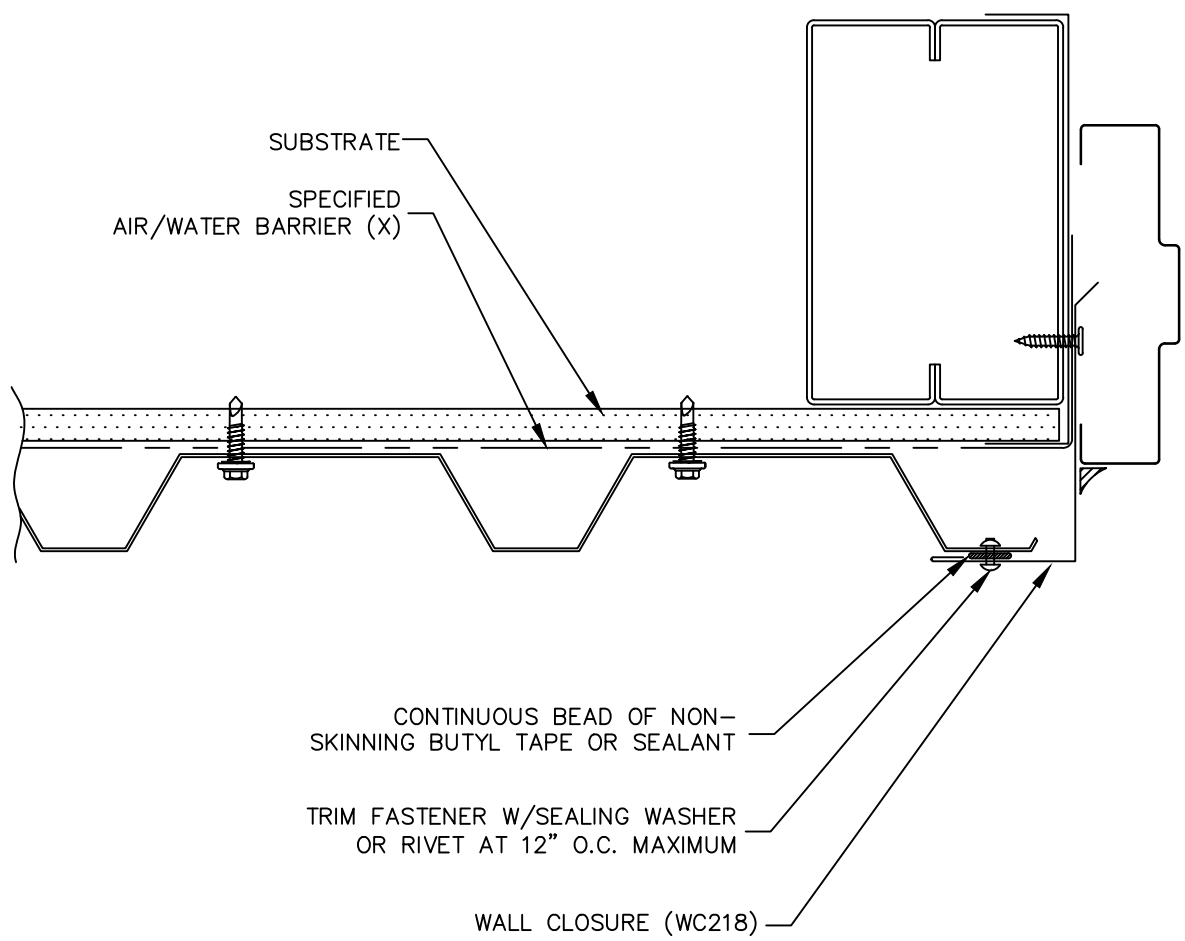
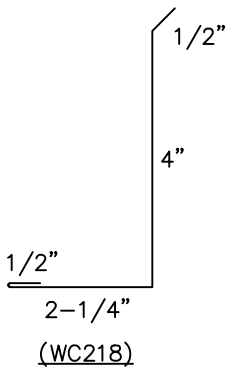

(X) - NOT BY AEP SPAN



REVERSED
BOX RIB

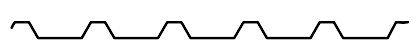

DOOR / WINDOW
(JAMB)



RBR-30

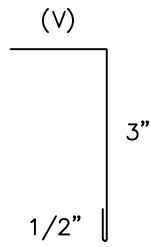

WALL CLOSURE

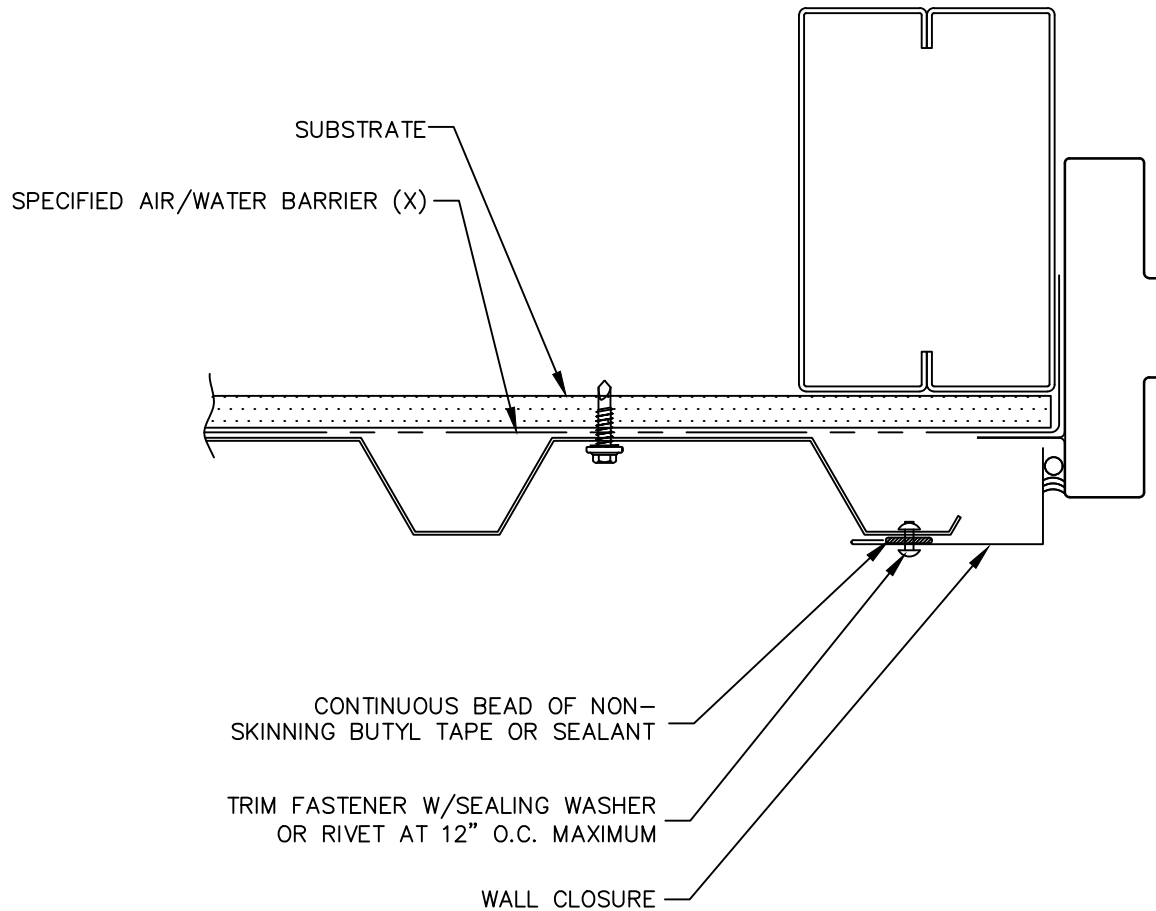

(X) - NOT BY AEP SPAN

(V) - DIMENSIONS VARY BASED ON PROJECT CONDITIONS



**REVERSED
BOX RIB**



**OPENING, JAMB
(NAIL FIN)**



RBR-31

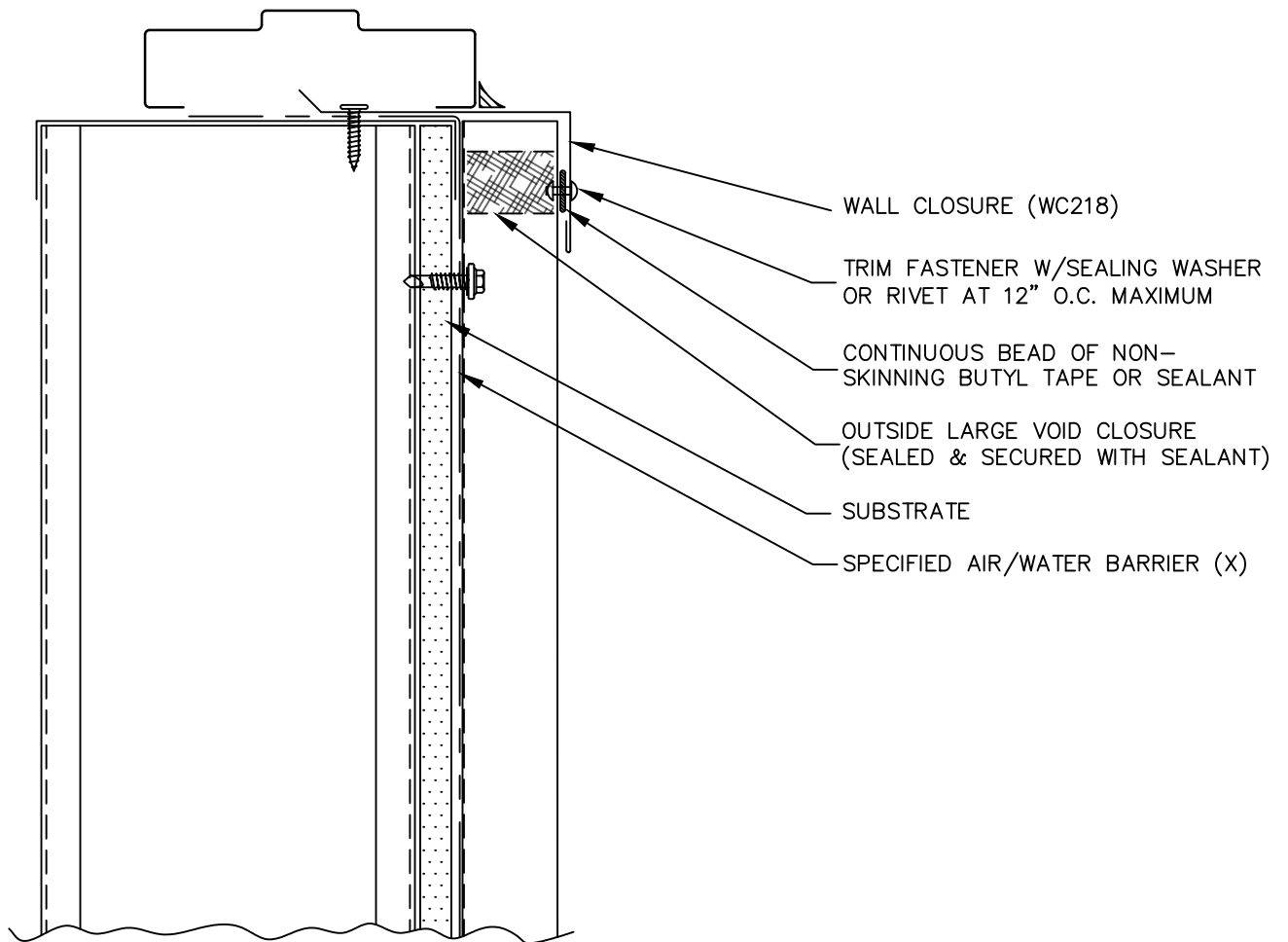
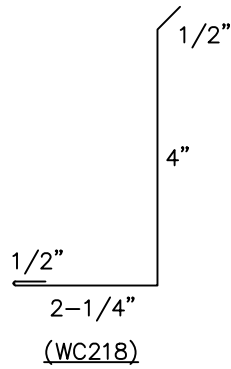

(X) - NOT BY AEP SPAN



REVERSED
BOX RIB



DOOR / WINDOW
(SILL)



RBR-32

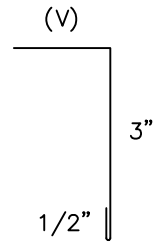

WALL CLOSURE

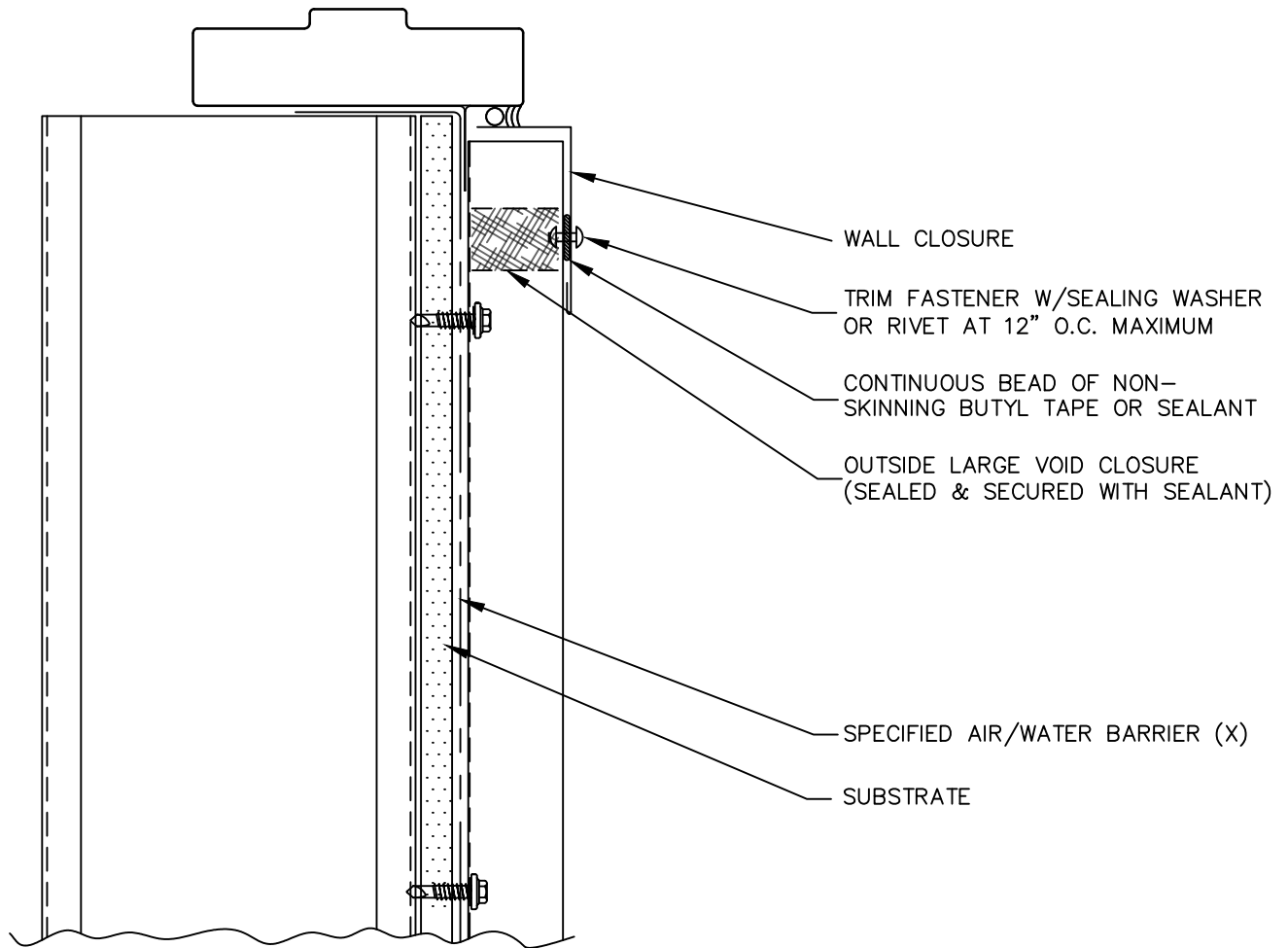

(X) - NOT BY AEP SPAN

(V) - DIMENSIONS VARY BASED ON PROJECT CONDITIONS



REVERSED
BOX RIB



OPENING, SILL
(NAIL FIN)



RBR-33

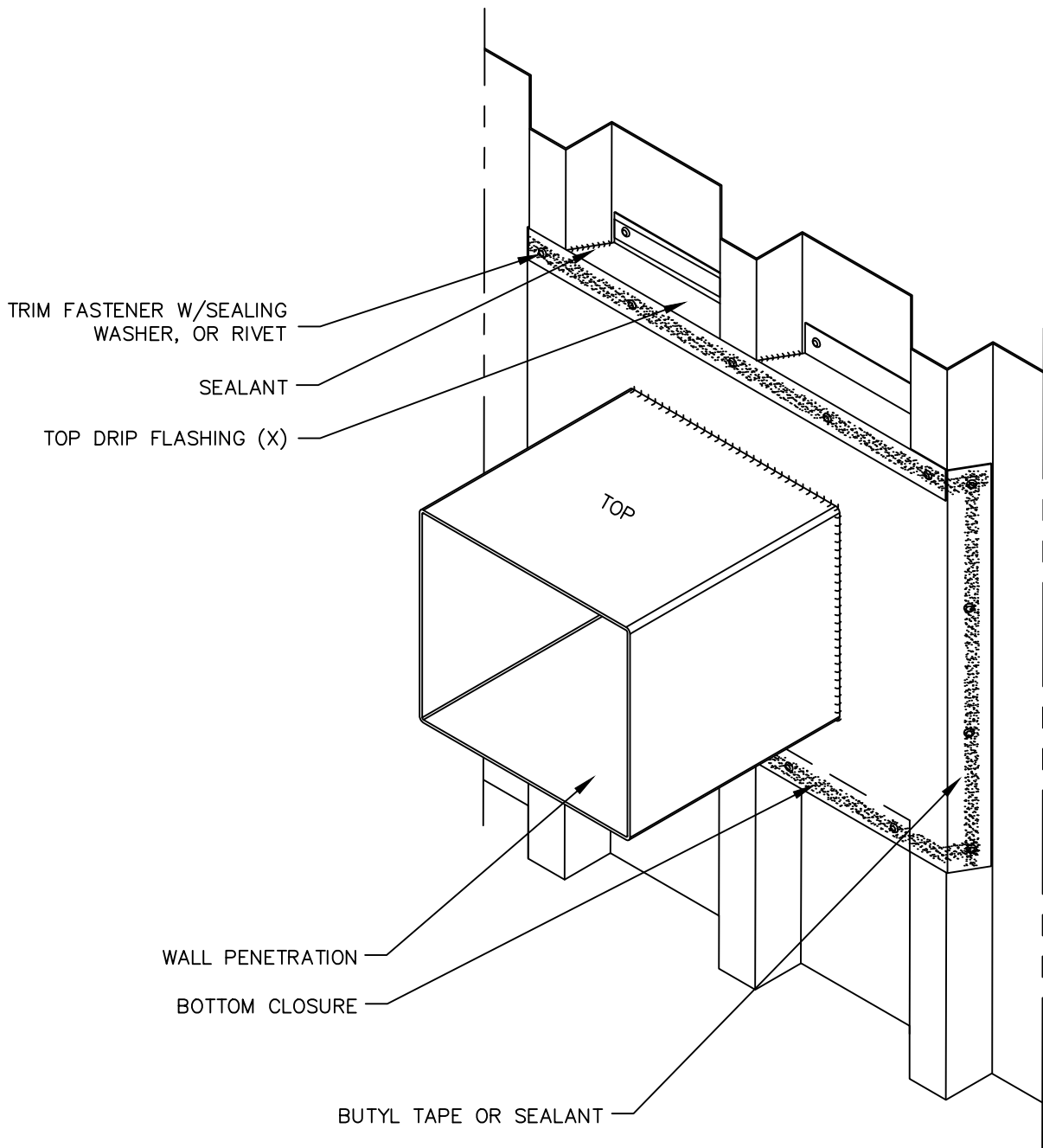

(X) – NOT BY AEP SPAN



REVERSED BOX RIB



PENETRATION (3D)

RBR-34

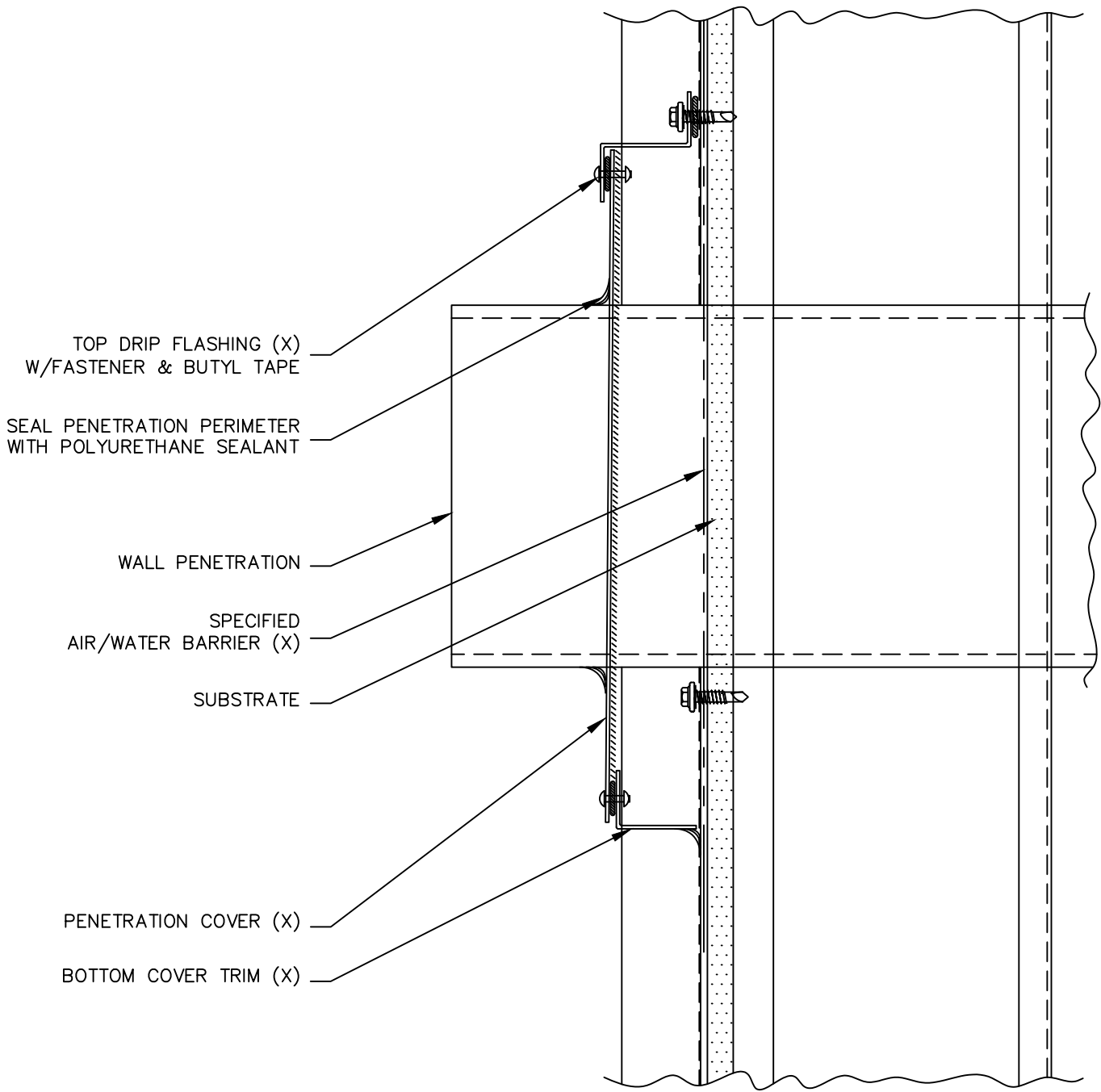

TOP DRIP FLASHING (X)
W/FASTENER & BUTYL TAPE

SEAL PENETRATION PERIMETER
WITH POLYURETHANE SEALANT

WALL PENETRATION

SPECIFIED
AIR/WATER BARRIER (X)

SUBSTRATE

PENETRATION COVER (X)

BOTTOM COVER TRIM (X)

(X) – NOT BY AEP SPAN



**REVERSED
BOX RIB**



PENETRATION (2D)

index

RBR-35

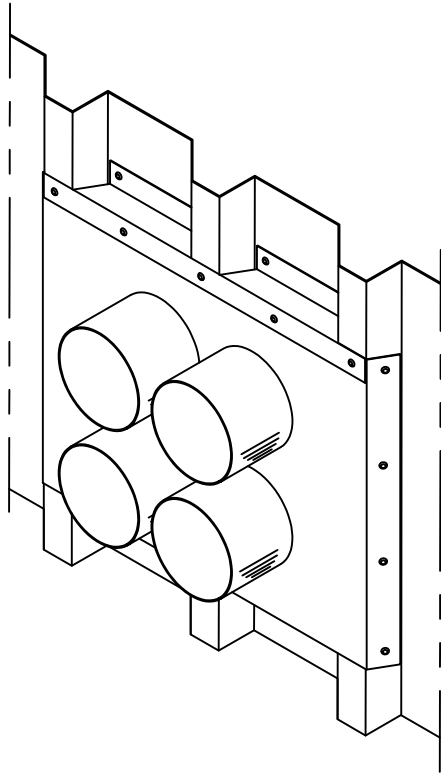

AC PIPING PENETRATION

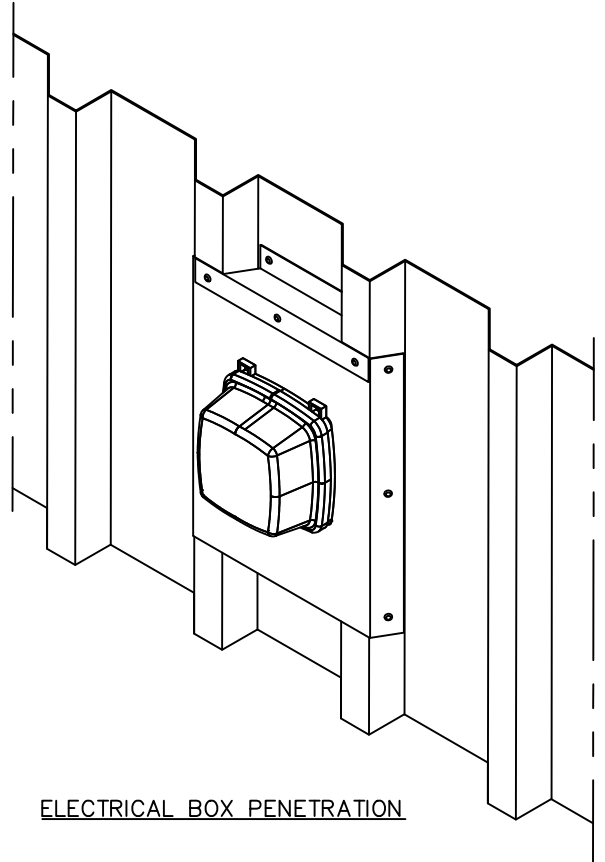

ELECTRICAL BOX PENETRATION

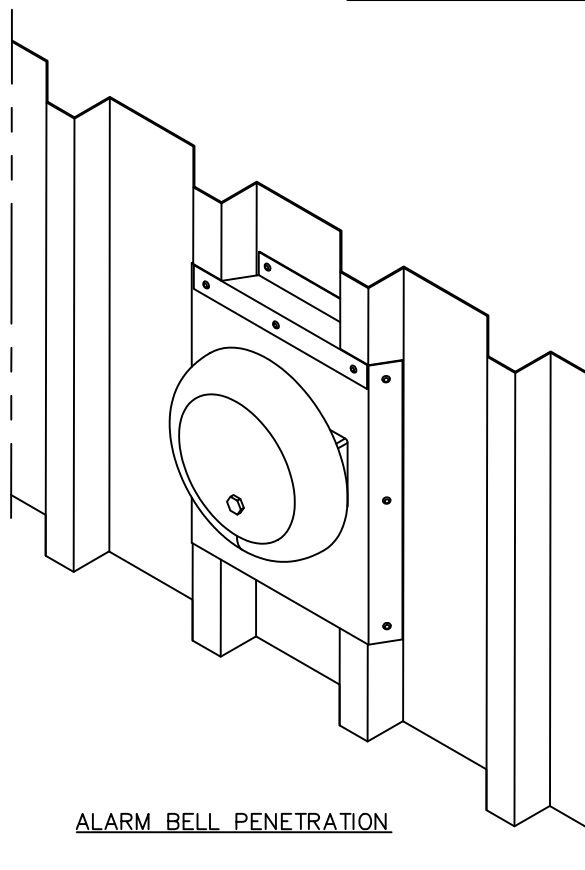

ALARM BELL PENETRATION



REVERSED
BOX RIB



PENETRATION (3D)
EXAMPLES



RBR-36

HORIZONTAL WALL DETAILS



REVERSED
BOX RIB



RBR-37

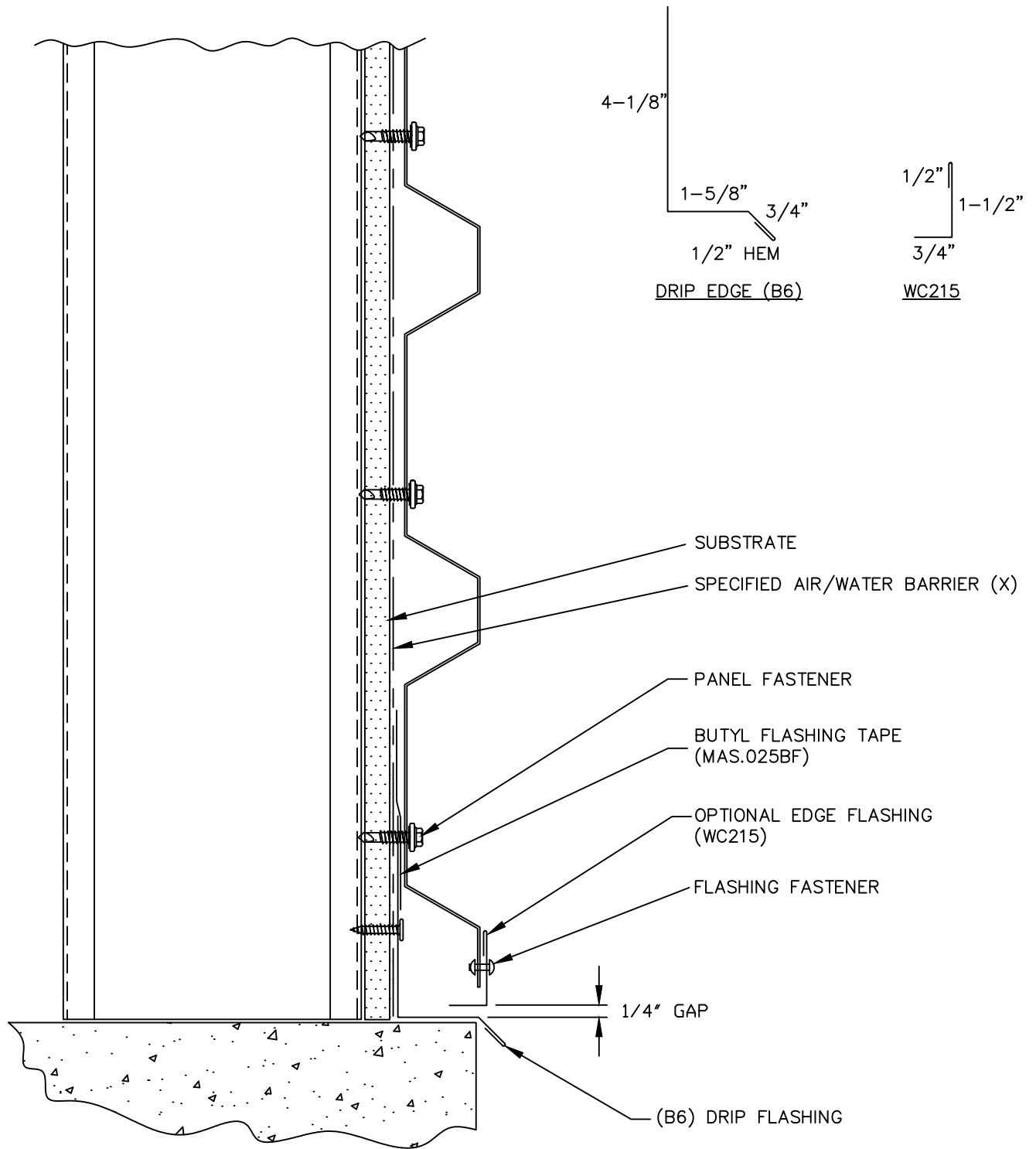

(X) - NOT BY AEP SPAN

HORIZONTAL PANELS ARE INSTALLED FROM GROUND TO EAVE.



REVERSED
BOX RIB



BASE



RBR-38

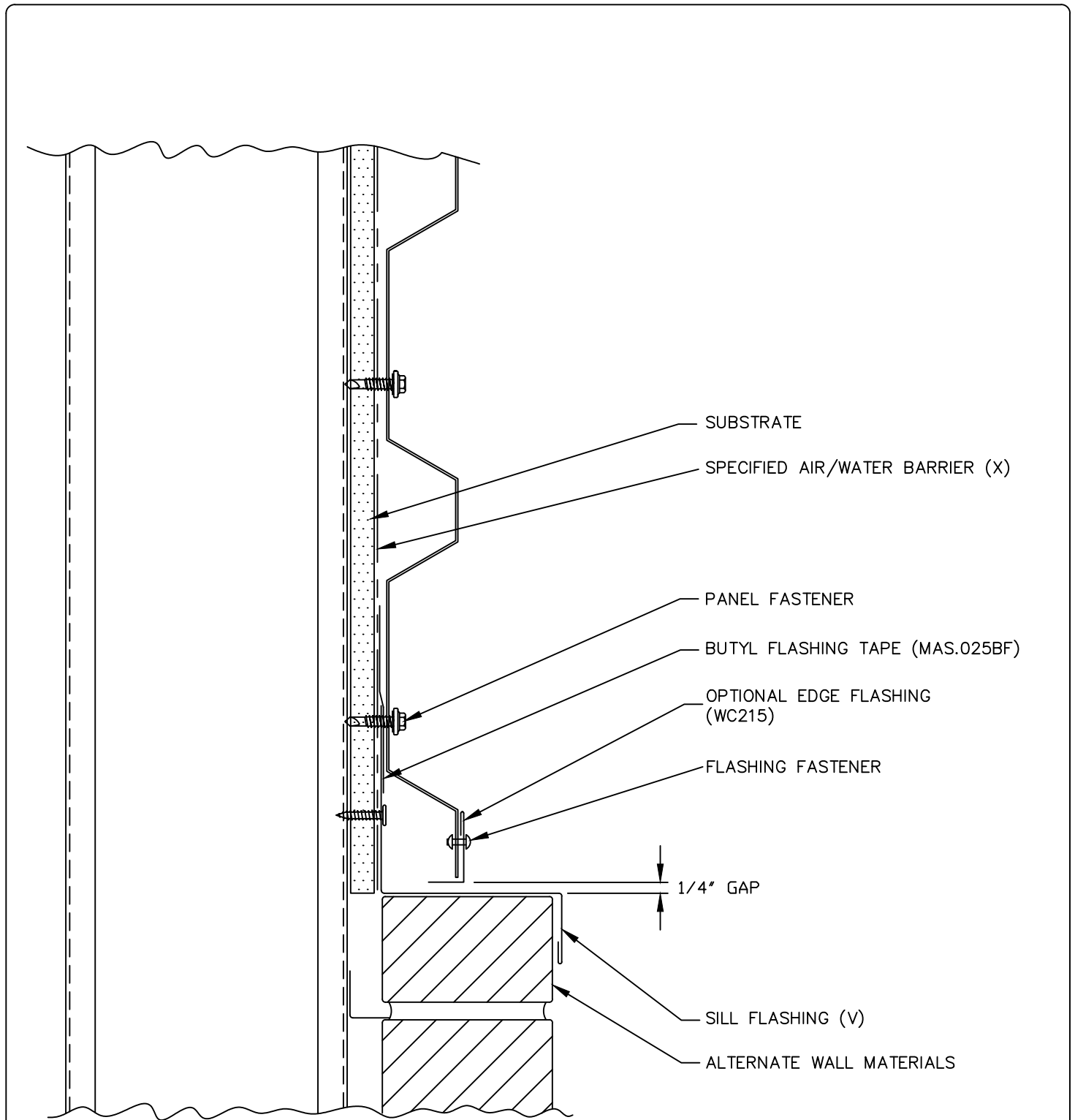

(X) - NOT BY AEP SPAN

(V) - DIMENSIONS VARY BASED ON PROJECT CONDITIONS



REVERSED BOX RIB



SILL

RBR-39

INSIDE SMALL VOID CLOSURE
(SEALED & SECURED WITH SEALANT)

EAVE FLASHING (V)

TRIM FASTENER W/SEALING WASHER
OR RIVET AT 12" O.C. MAXIMUM

CONTINUOUS BEAD OF NON-
SKINNING BUTYL TAPE OR SEALANT

PANEL FASTENER

SPECIFIED AIR/WATER BARRIER (X)

SUBSTRATE

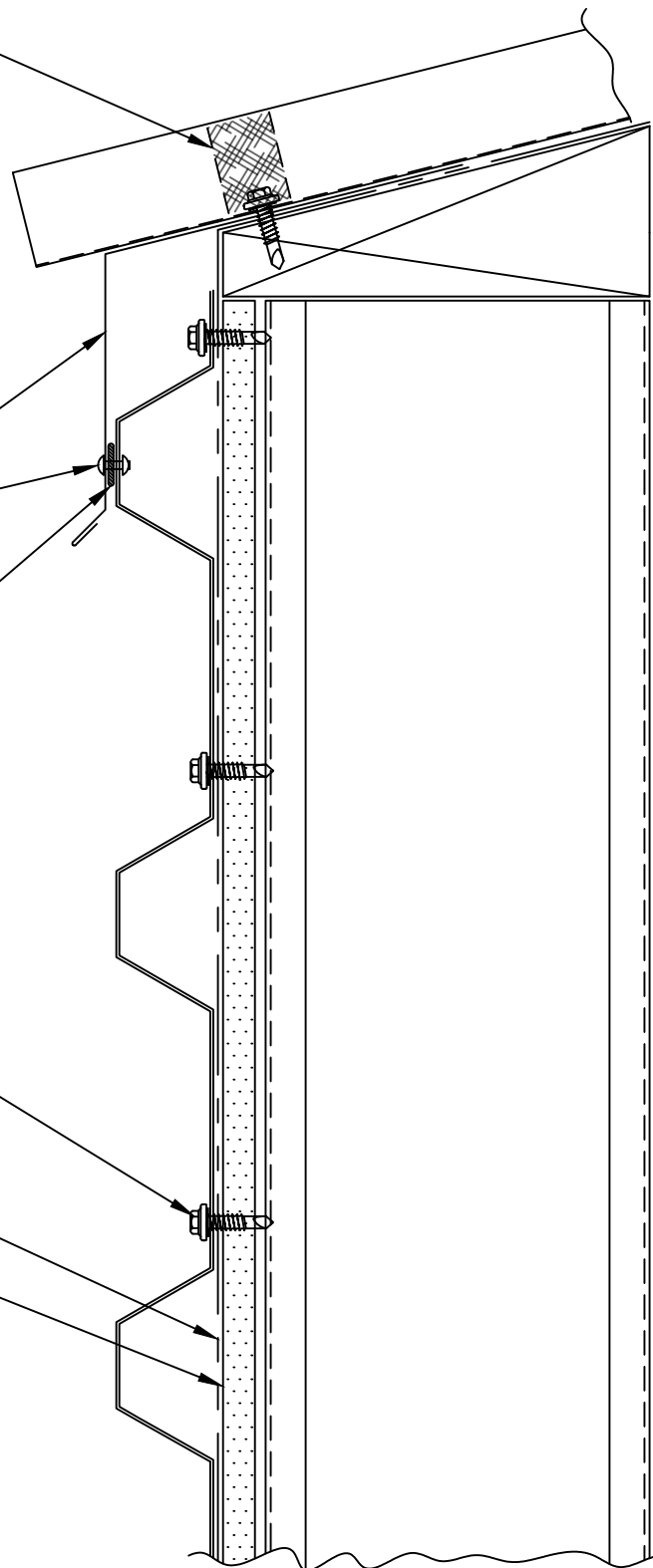

(X) - NOT BY AEP SPAN

(V) - DIMENSIONS VARY BASED ON PROJECT CONDITIONS



REVERSED
BOX RIB



index

EAVE / FASCIA

RBR-40

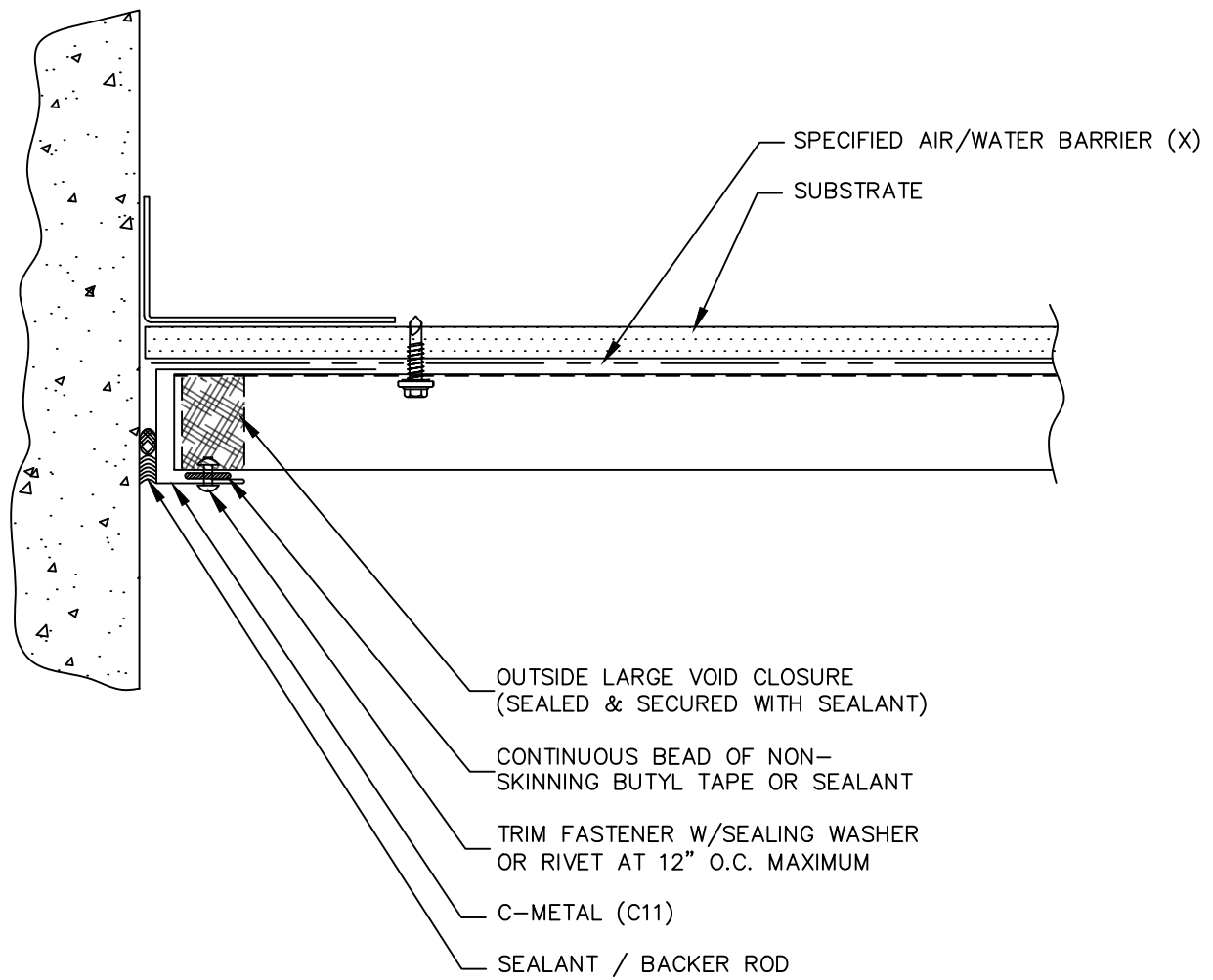
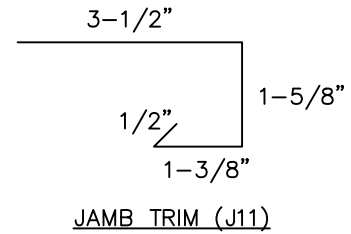
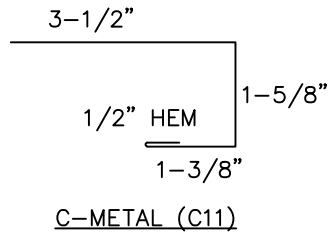

(X) - NOT BY AEP SPAN



REVERSED
BOX RIB

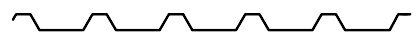

END WALL



RBR-41

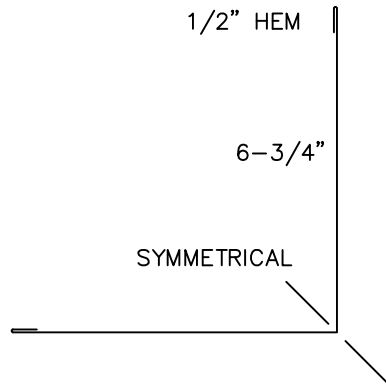

OUTSIDE CORNER (OC11)

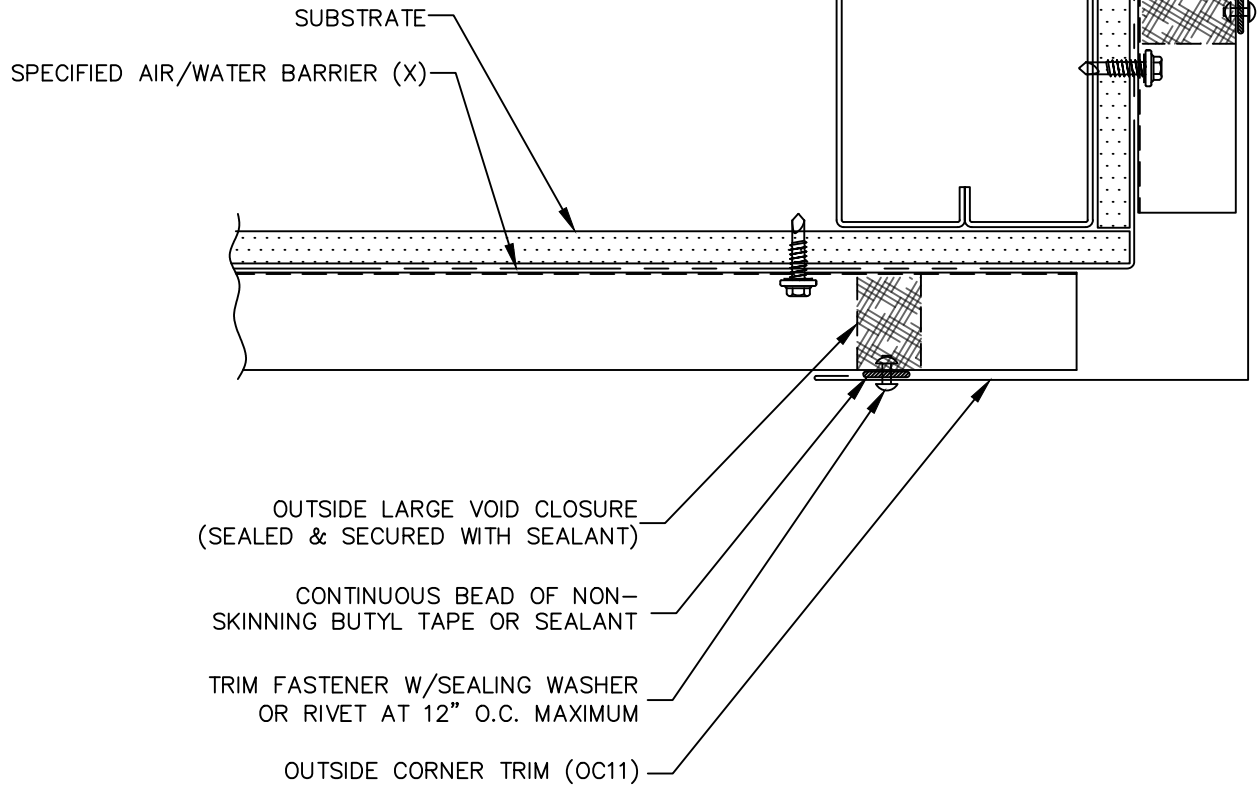

(X) – NOT BY AEP SPAN



REVERSED
BOX RIB



OUTSIDE CORNER

RBR-42

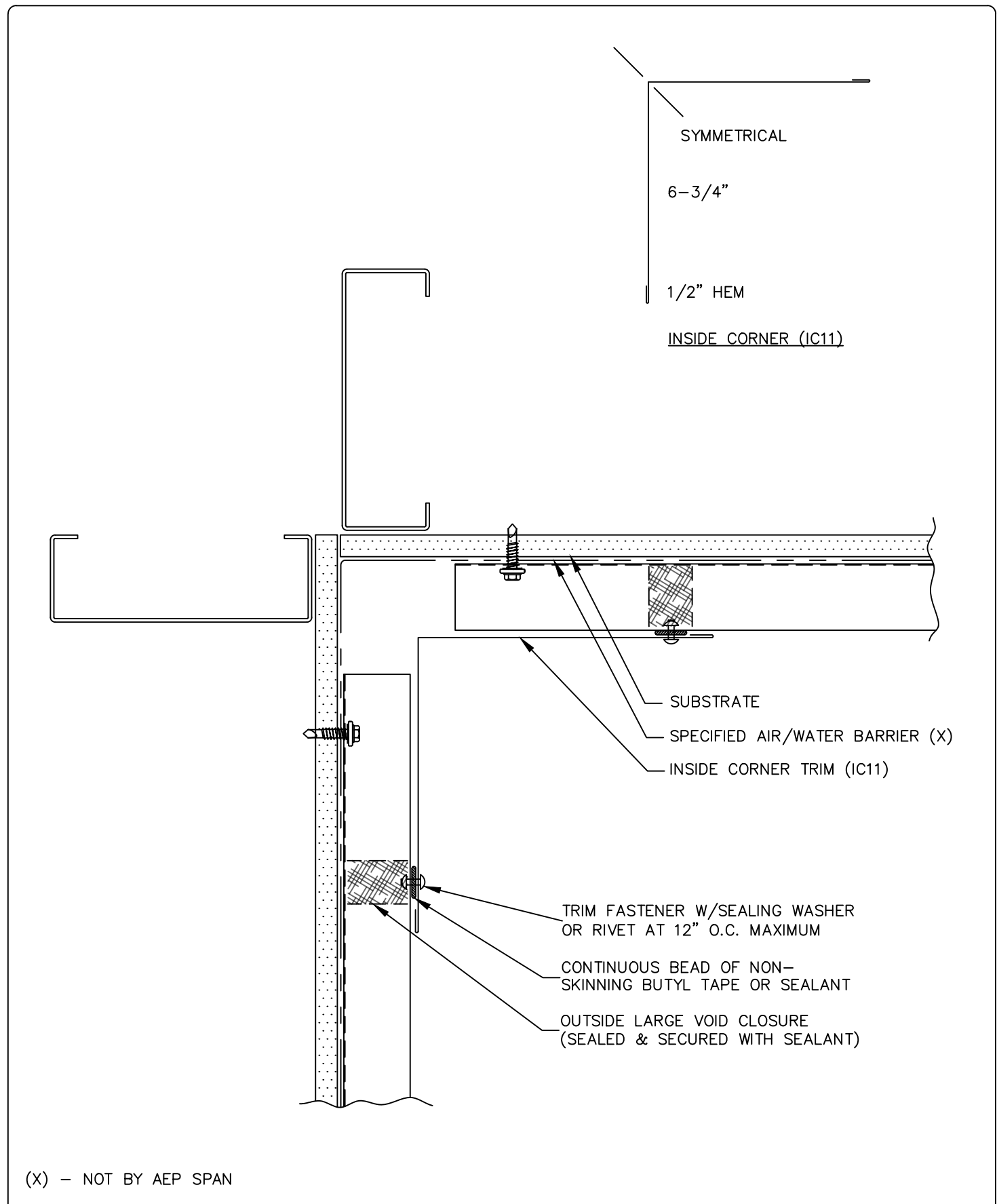

(X) - NOT BY AEP SPAN



REVERSED
BOX RIB



INSIDE CORNER



RBR-43

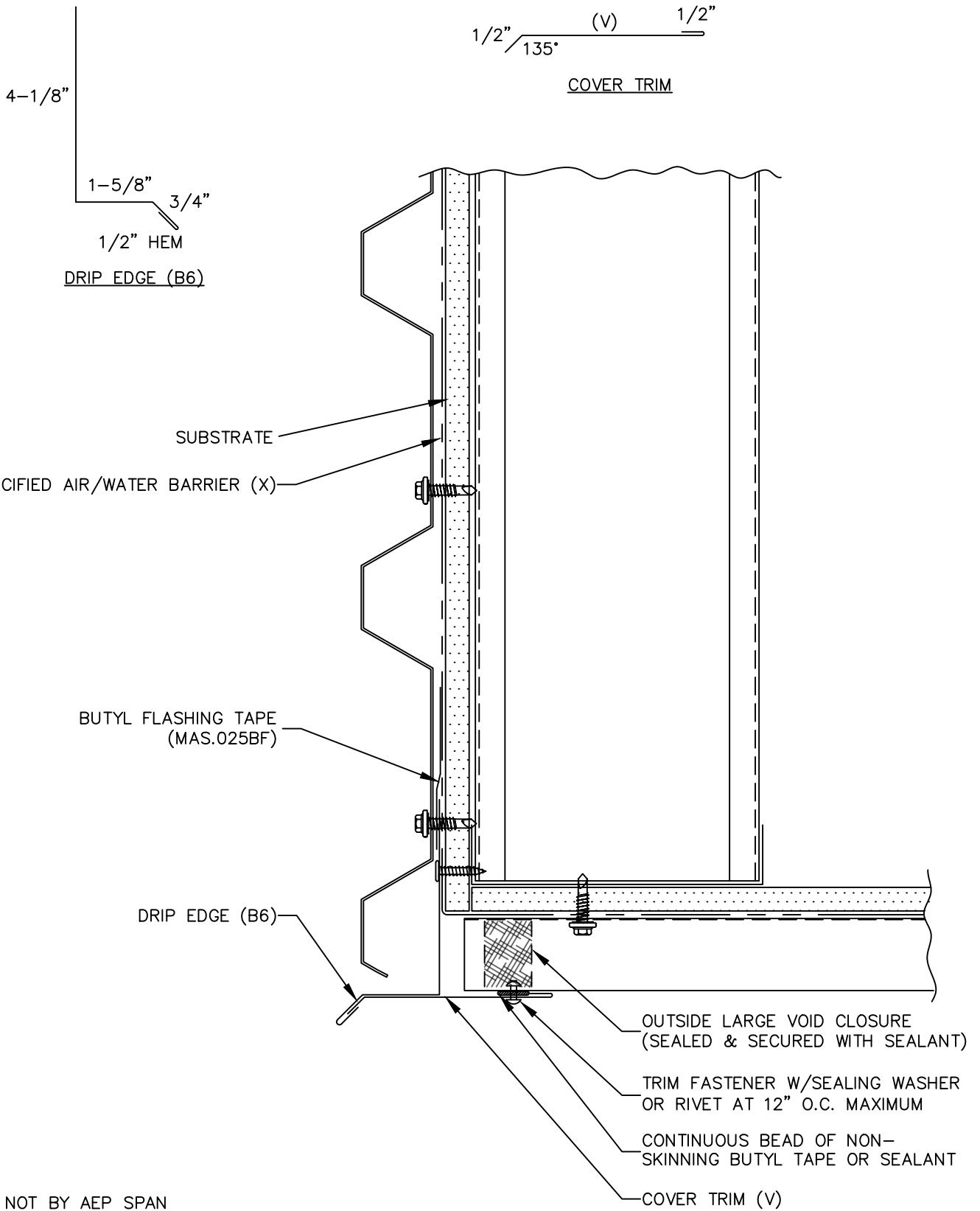

(X) - NOT BY AEP SPAN
 (V) - DIMENSIONS VARY BASED ON PROJECT CONDITIONS



REVERSED BOX RIB



SOFFIT (FRONT)



RBR-44

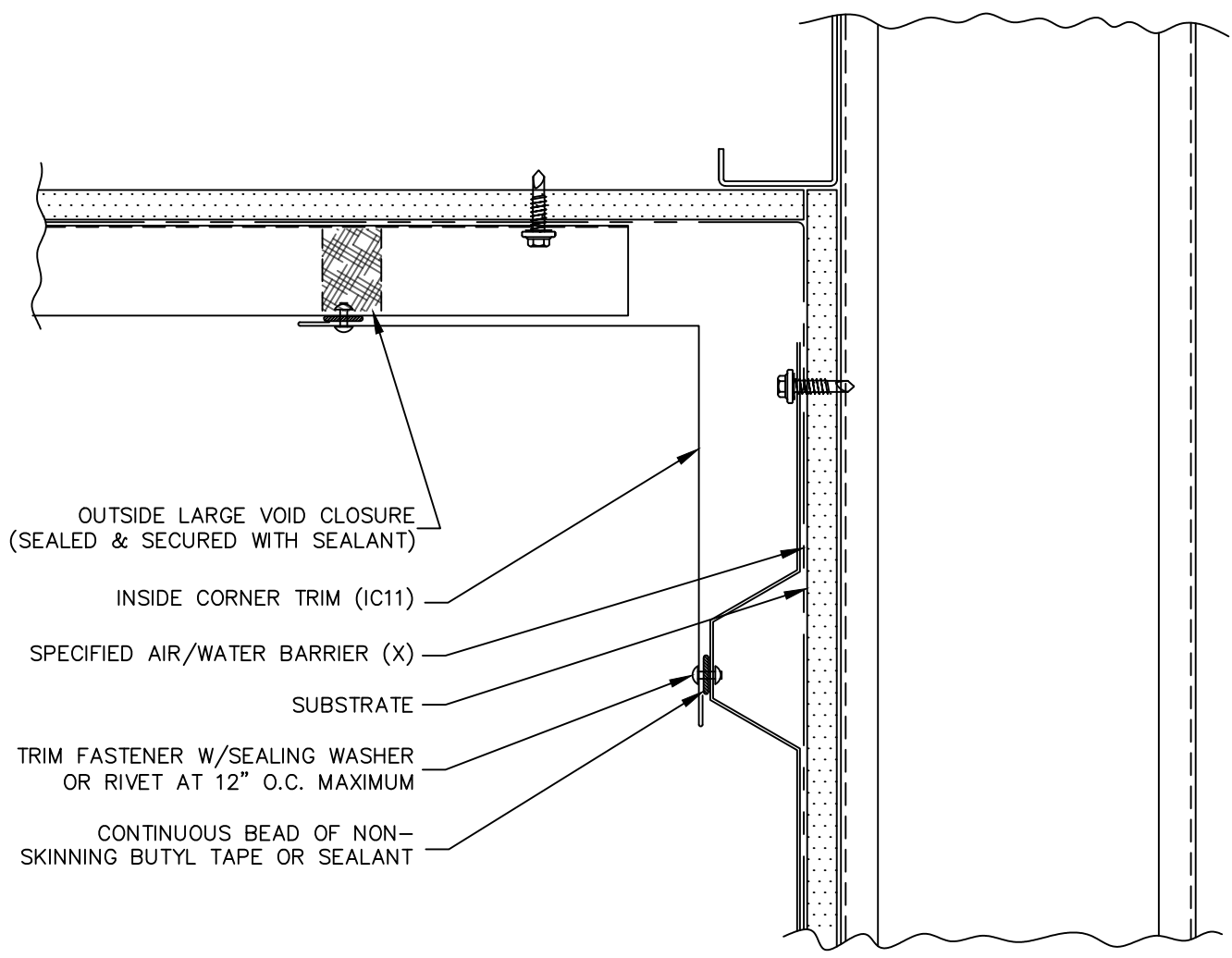
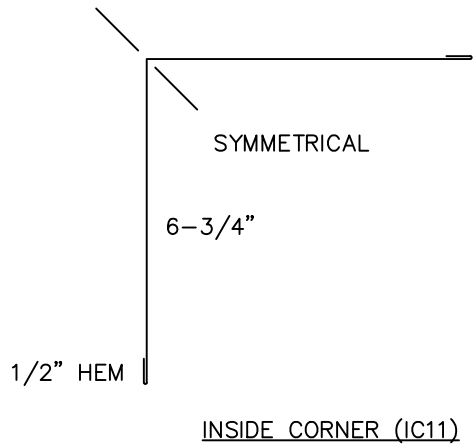

(X) - NOT BY AEP SPAN



REVERSED
BOX RIB

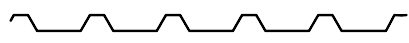

SOFFIT (BACK)



RBR-45

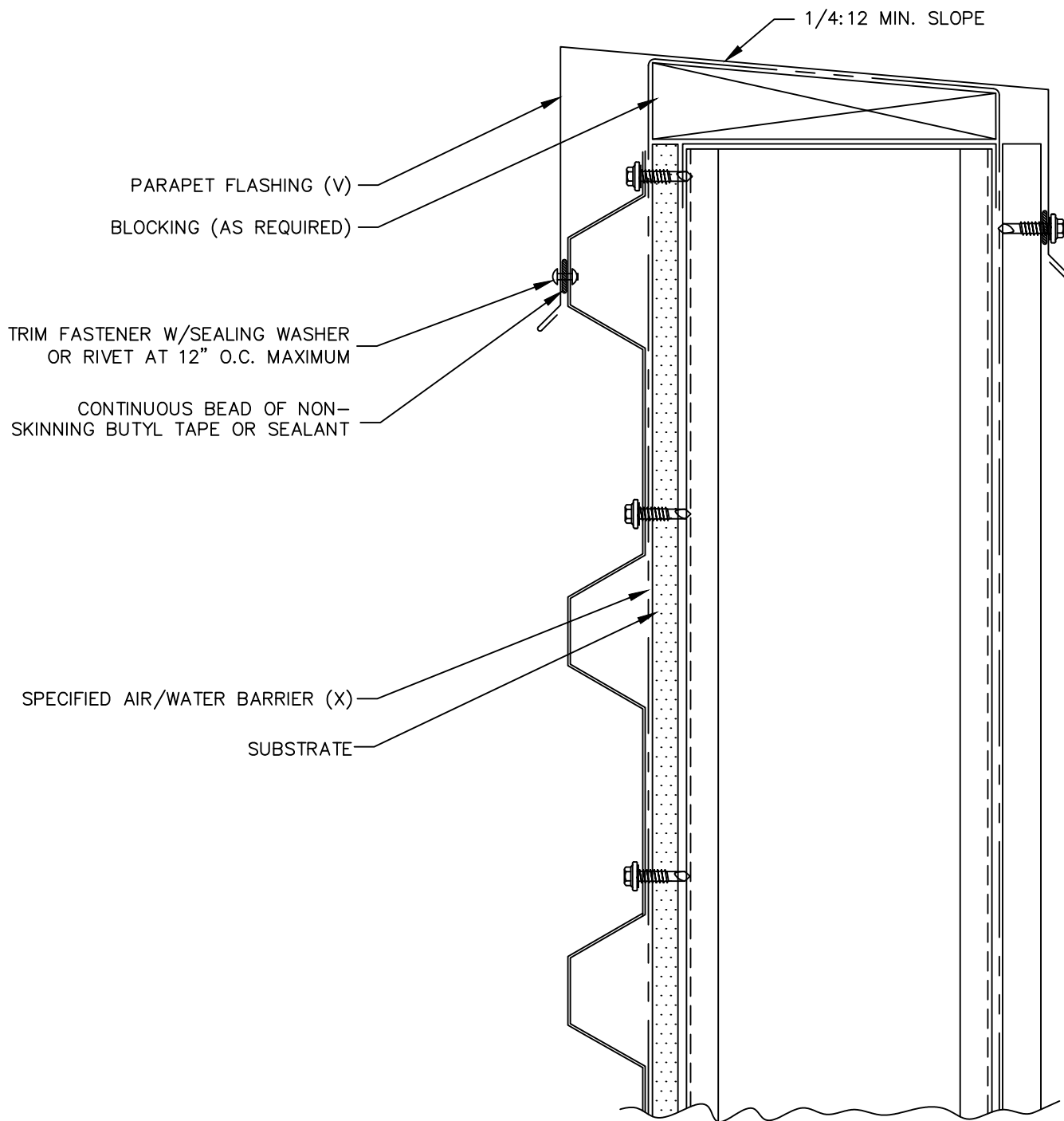

(X) - NOT BY AEP SPAN
 (V) - DIMENSIONS VARY BASED ON PROJECT CONDITIONS



REVERSED
 BOX RIB



PARAPET



RBR-46

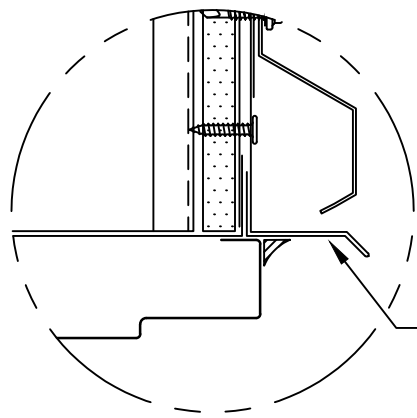
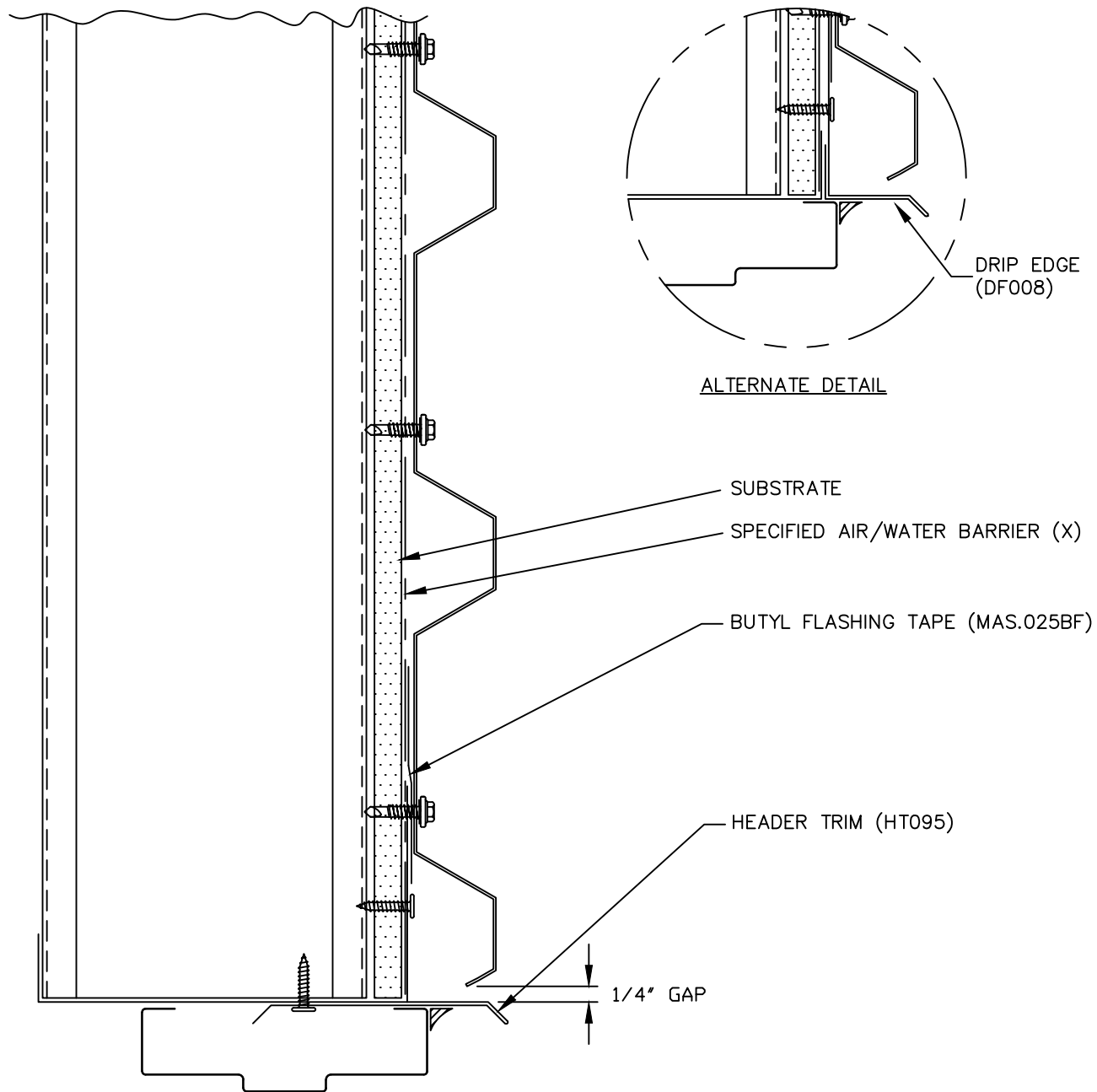

ALTERNATE DETAIL

SUBSTRATE

SPECIFIED AIR/WATER BARRIER (X)

BUTYL FLASHING TAPE (MAS.025BF)

HEADER TRIM (HT095)

1/4" GAP

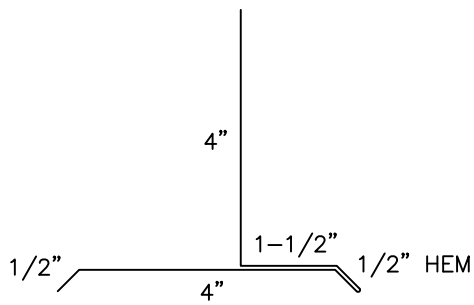

HEADER TRIM (HT095)

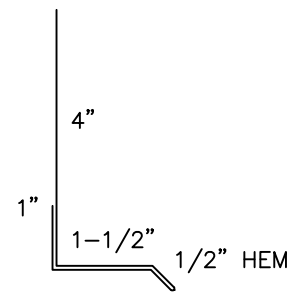

DRIP EDGE (DF008)

(X) - NOT BY AEP SPAN



REVERSED
BOX RIB

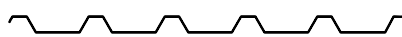

OPENING, HEAD



RBR-47

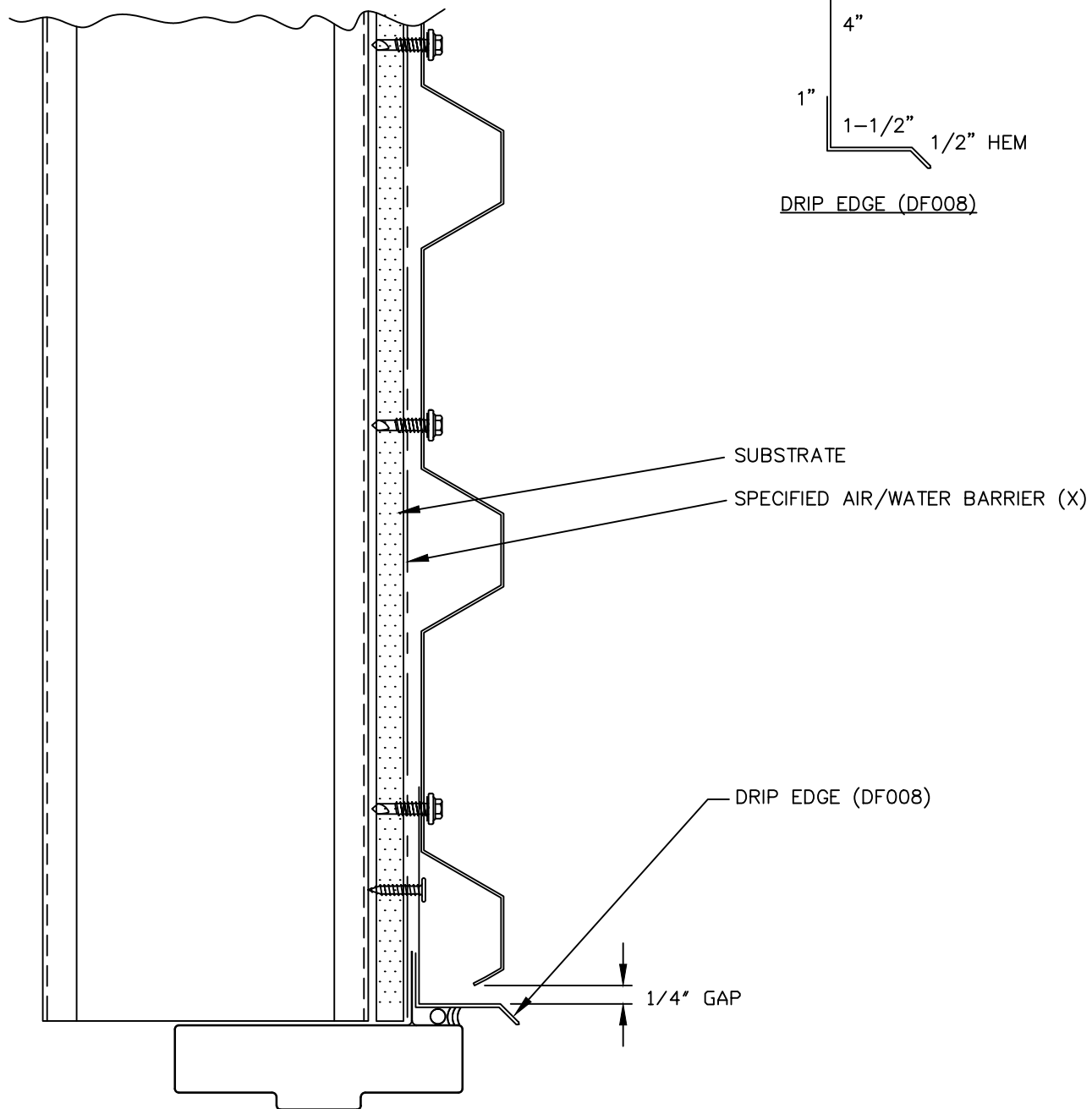

(X) - NOT BY AEP SPAN



REVERSED
BOX RIB



OPENING, HEAD
(NAIL FIN)



RBR-48

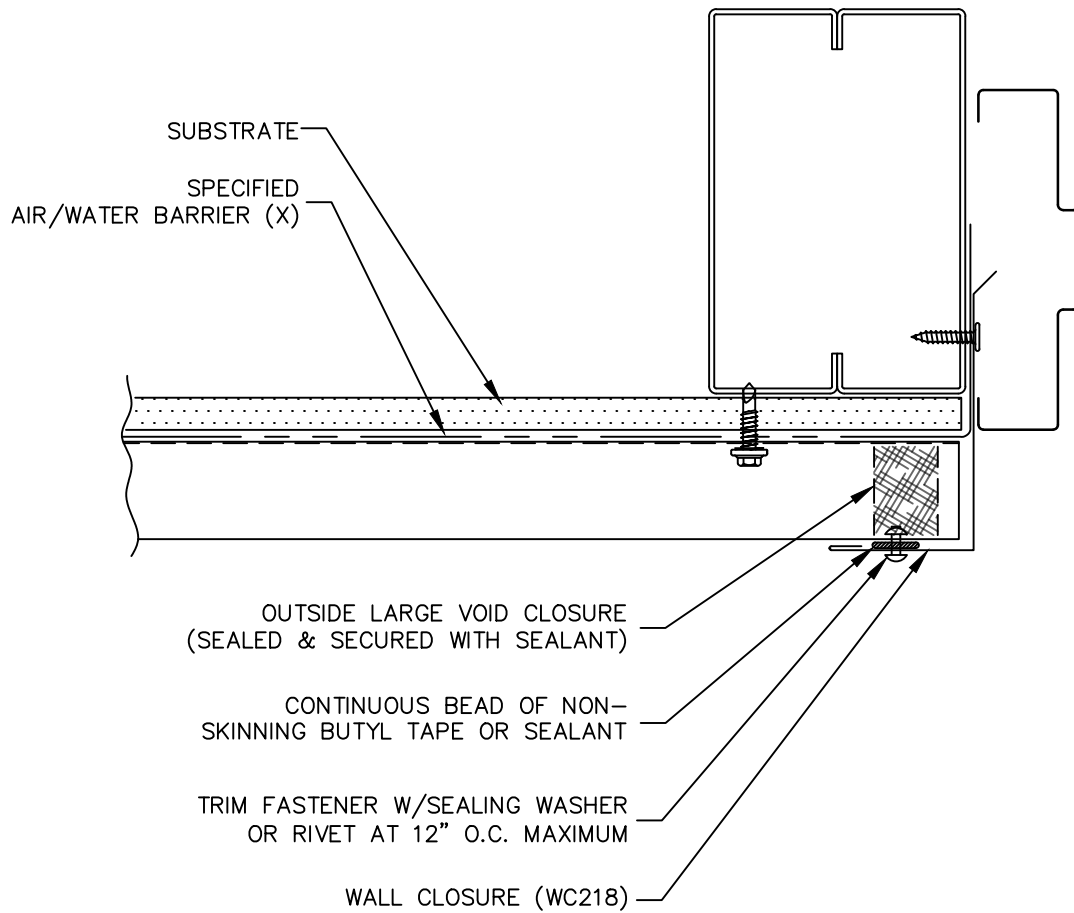
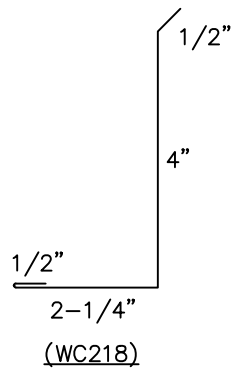

(X) - NOT BY AEP SPAN



REVERSED
BOX RIB



OPENING, JAMB



RBR-49

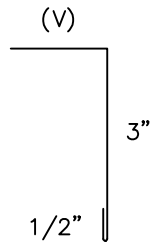

WALL CLOSURE

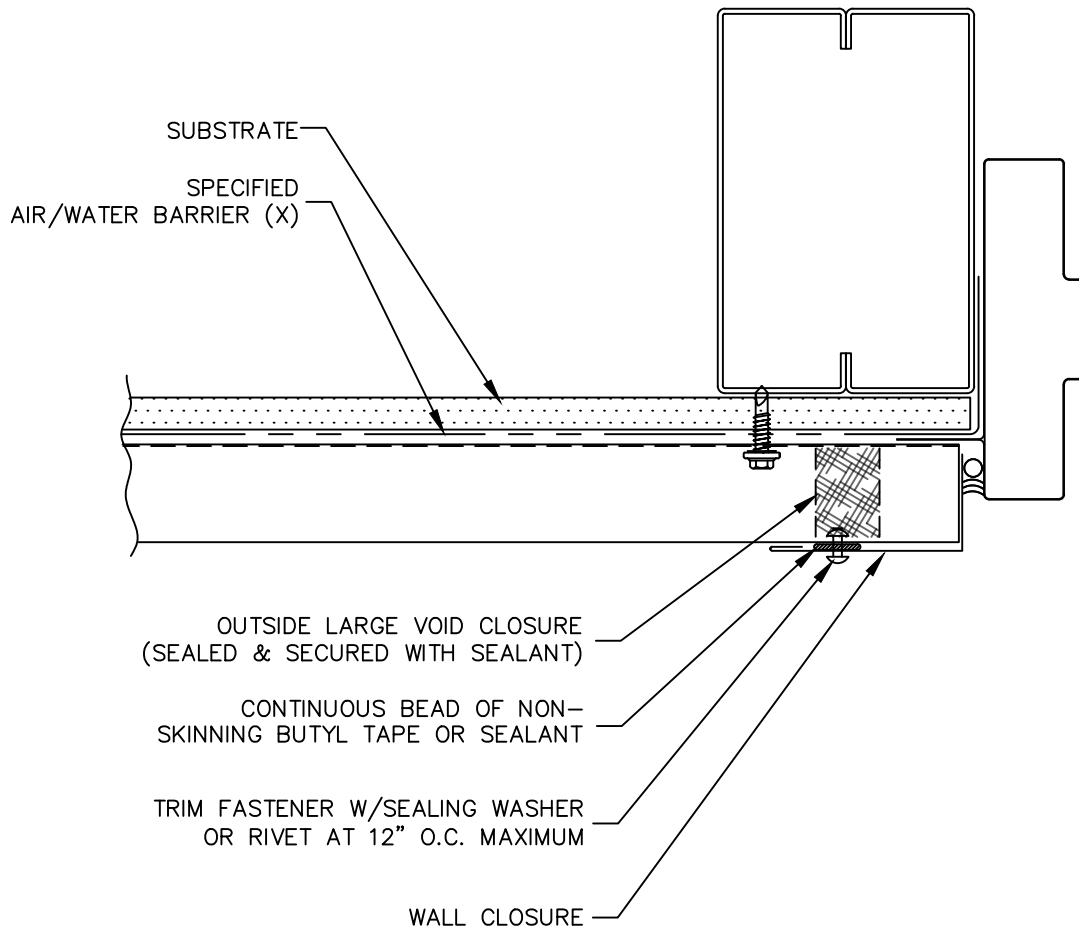

(X) - NOT BY AEP SPAN

(V) - DIMENSIONS VARY BASED ON PROJECT CONDITIONS



**REVERSED
BOX RIB**



**OPENING, JAMB
(NAIL FIN)**



RBR-50

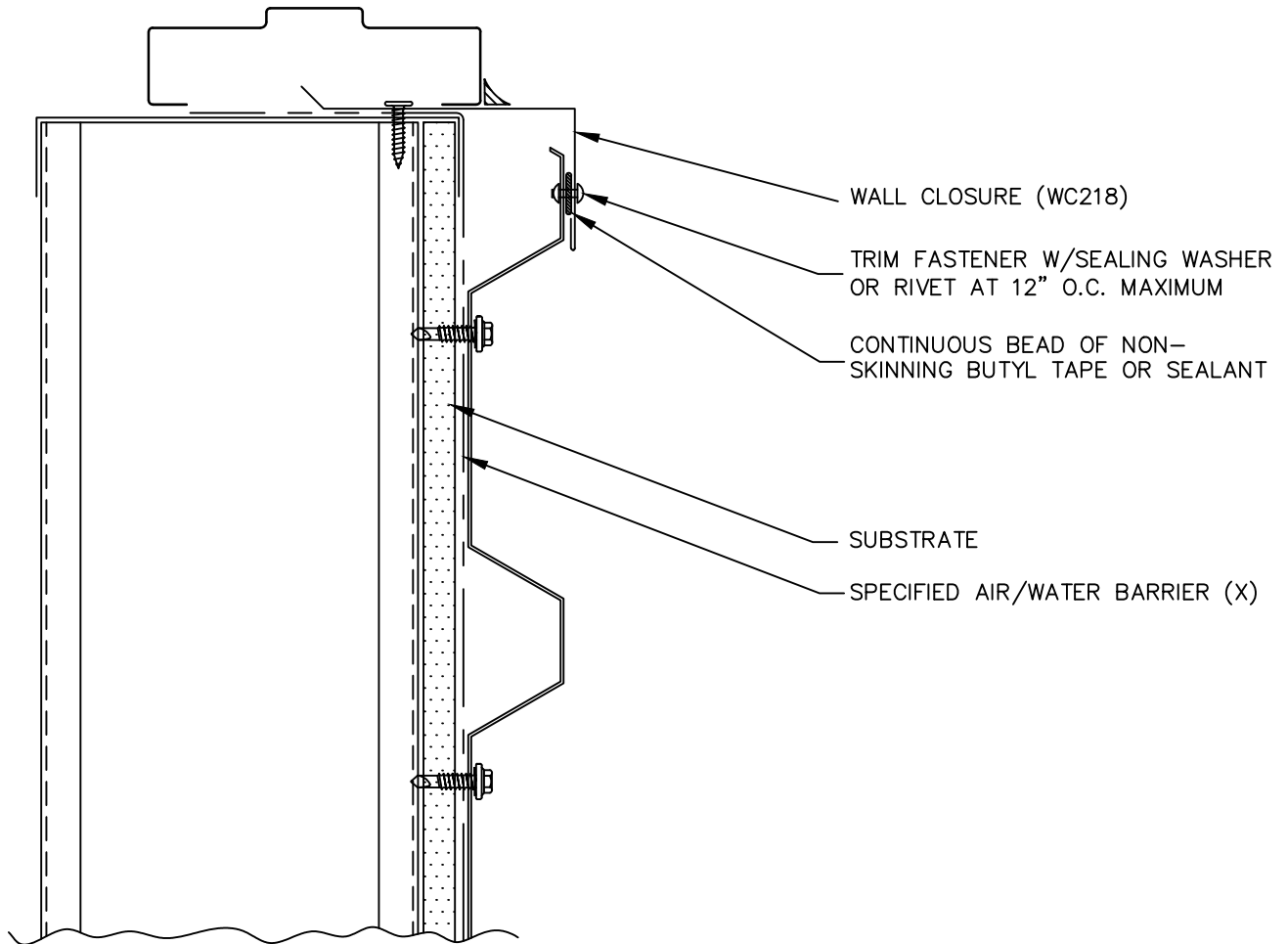
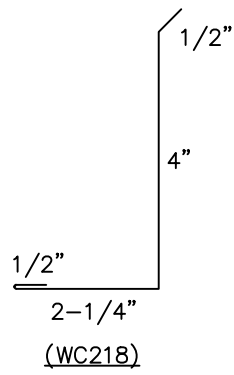

(X) - NOT BY AEP SPAN



REVERSED
BOX RIB



OPENING, SILL



RBR-51

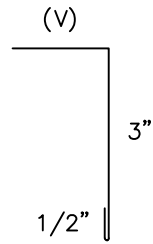

WALL CLOSURE

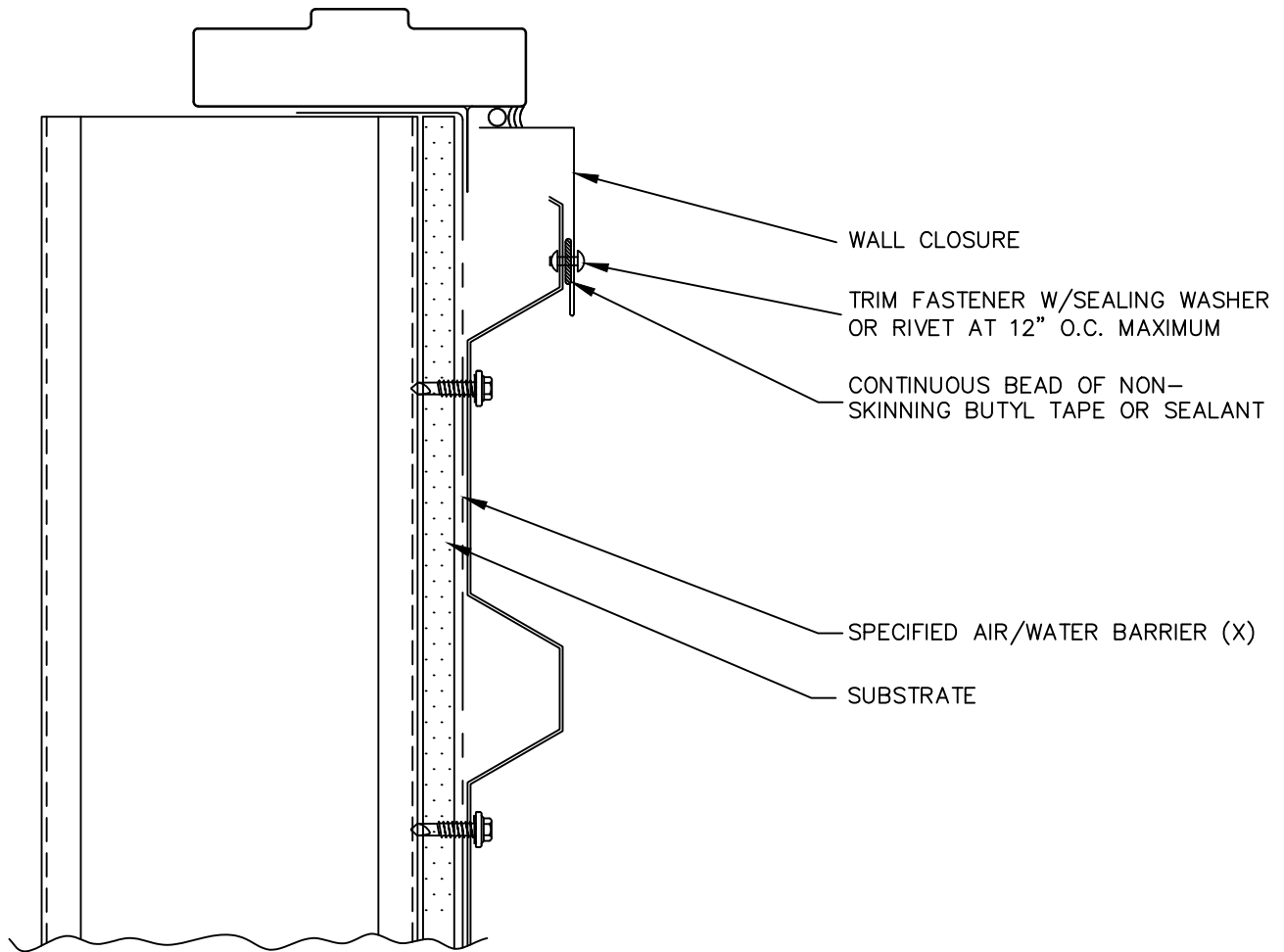

(X) - NOT BY AEP SPAN
 (V) - DIMENSIONS VARY BASED ON PROJECT CONDITIONS



**REVERSED
BOX RIB**



OPENING, SILL
(NAIL FIN)



RBR-52

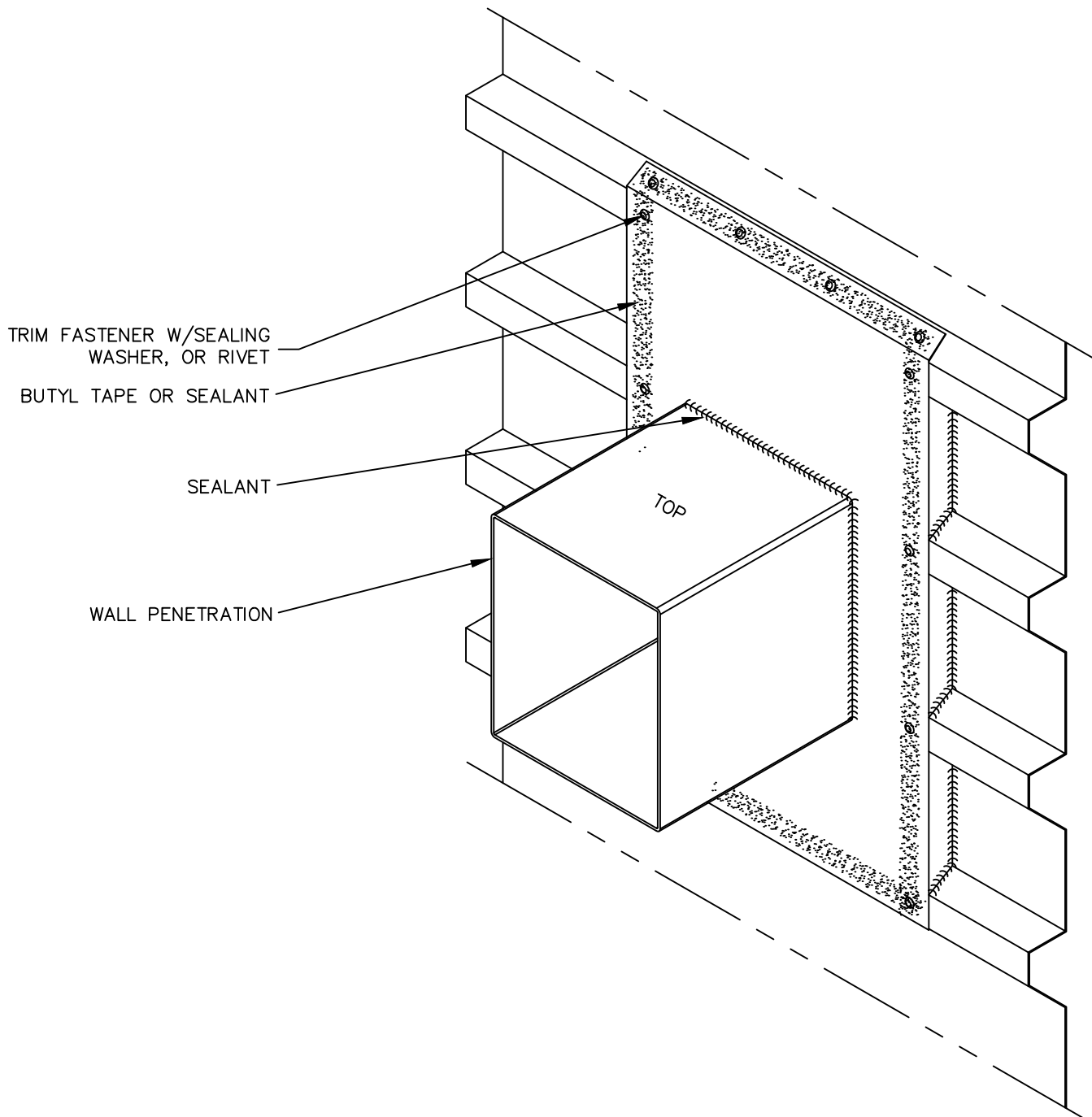

TRIM FASTENER W/SEALING
WASHER, OR RIVET

BUTYL TAPE OR SEALANT

SEALANT

WALL PENETRATION

TOP



REVERSED
BOX RIB

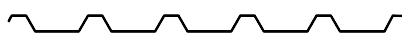

WALL PENETRATION (3D)



RBR-53

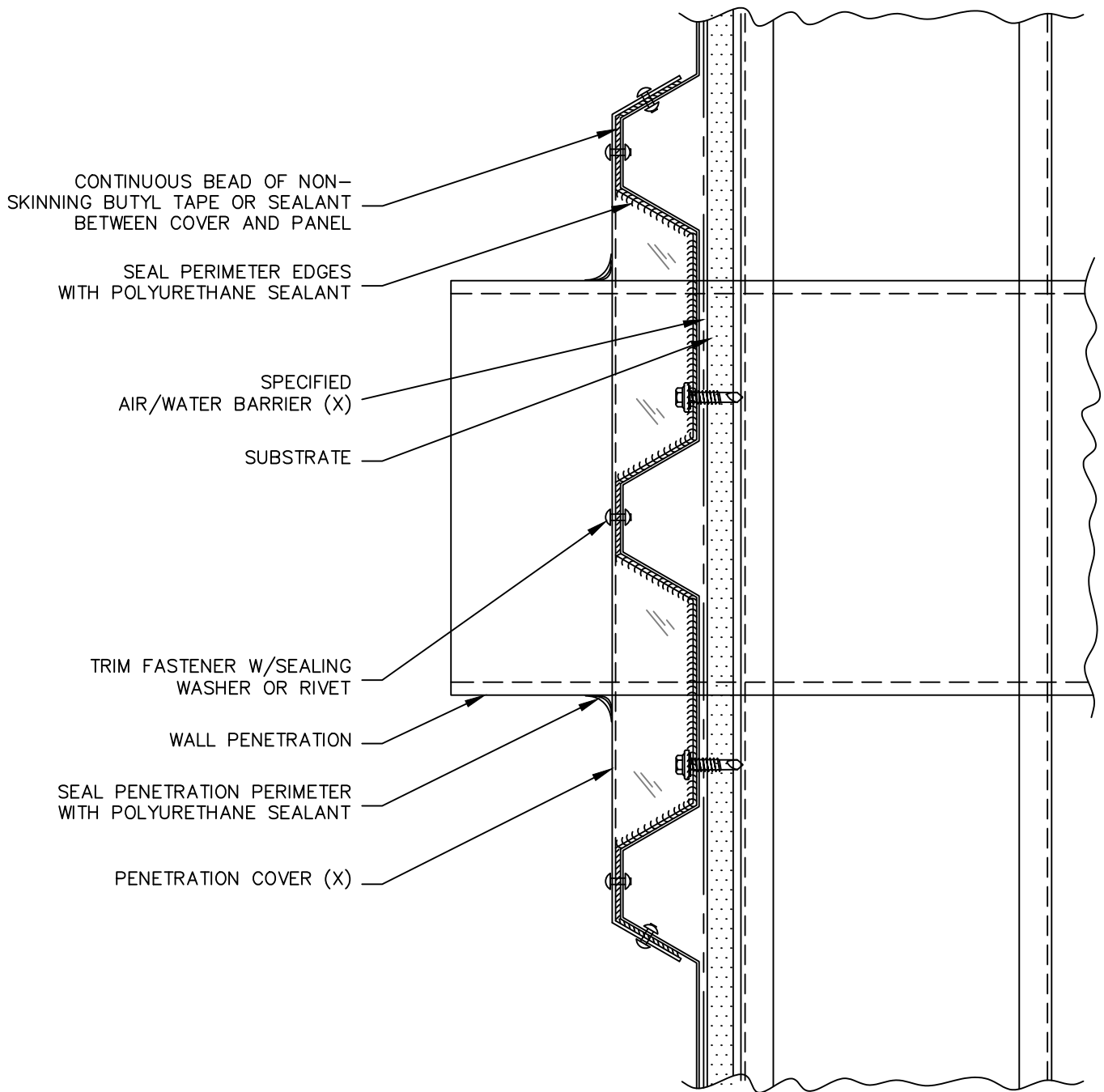

(X) – NOT BY AEP SPAN



REVERSED BOX RIB



PENETRATION (2D)



RBR-54

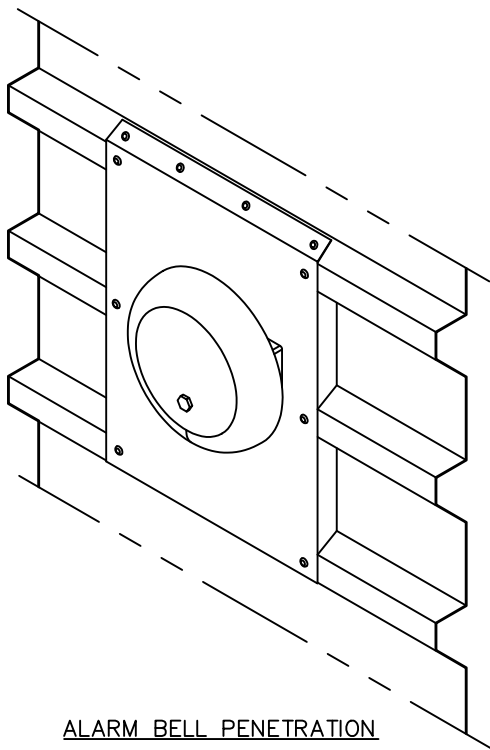

ALARM BELL PENETRATION

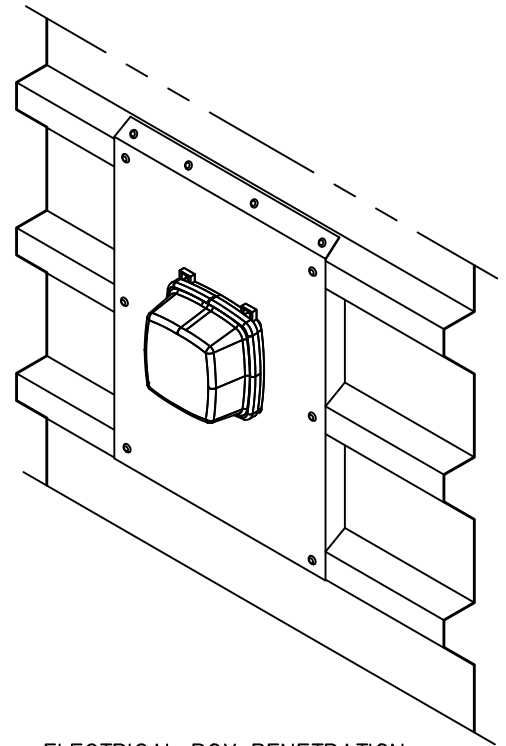

ELECTRICAL BOX PENETRATION

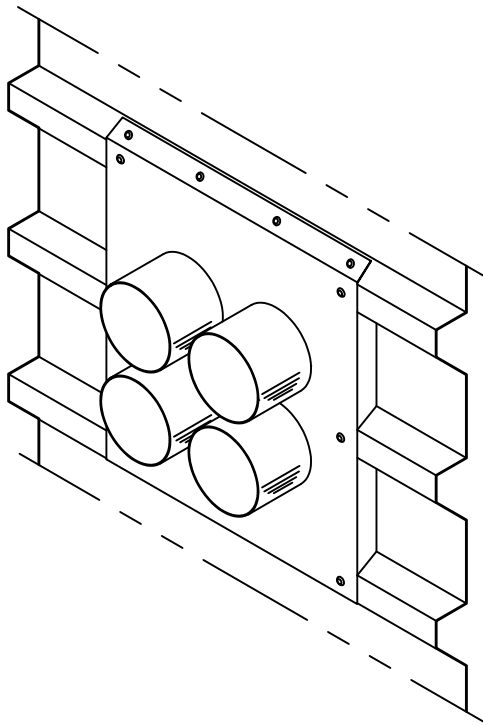

AC PIPING PENETRATION



**REVERSED
BOX RIB**



**PENETRATION (3D)
EXAMPLES**



RBR-55

MANUFACTURING FACILITY:

West Sacramento, California

2110 Enterprise Boulevard
West Sacramento, CA 95691

Tacoma, Washington

2141 Milwaukee Way
Tacoma, WA 98421

CUSTOMER SERVICE:

800-733-4955

Visit us at:

www.aepspan.com

